

TEAM LOSI



OWNER'S GUIDE

▶ Carefully read through all instructions to familiarize yourself with the parts, construction, techniques, and tuning tips outlined in this manual. Being able to grasp the overall design of the JRX-Pro before construction will ensure a smooth assembly.

▶ Take your time and pay close attention to details. Keep this guide for future reference.

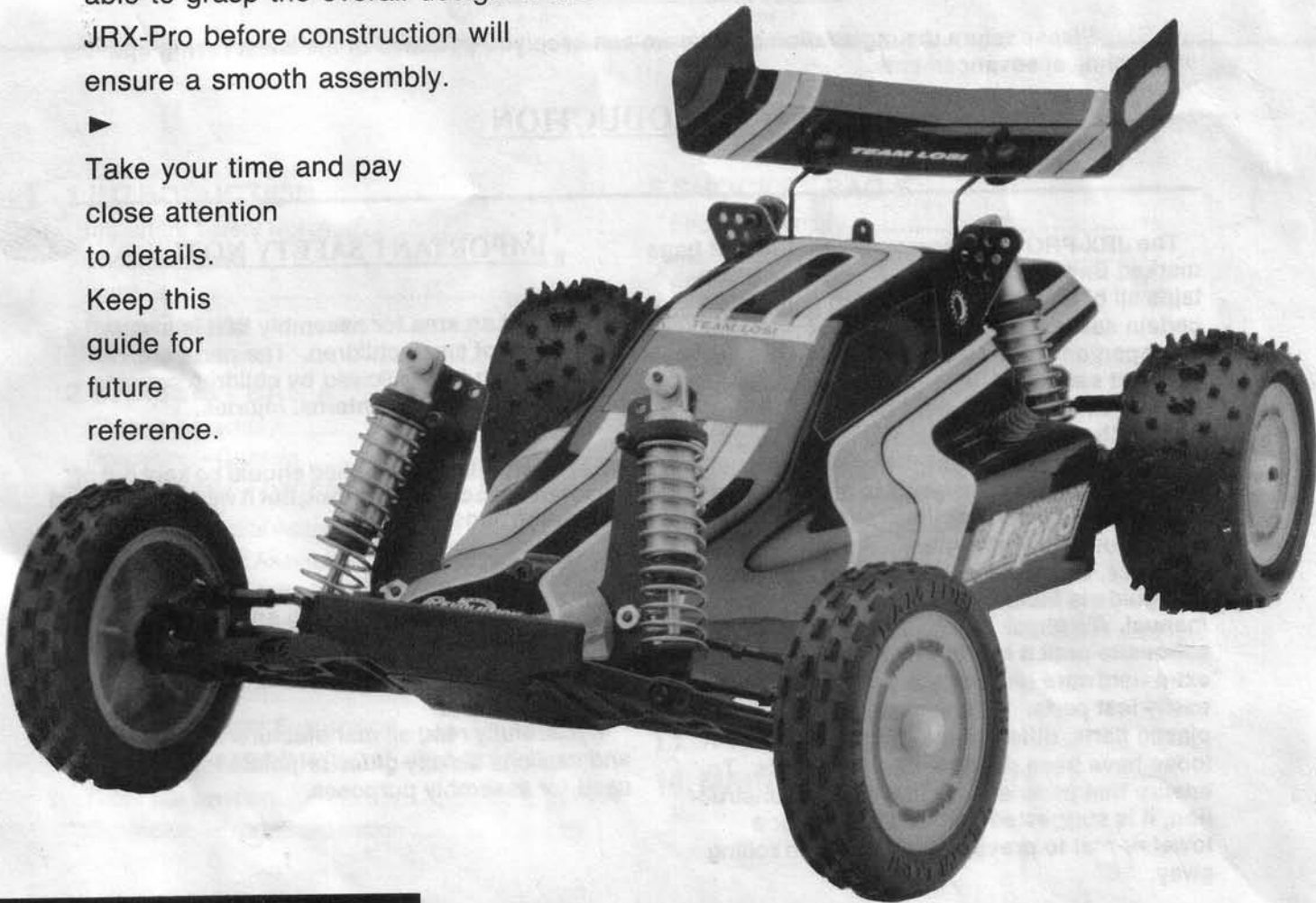

TEAM LOSI
PERFORMANCE

TEAM LOSI INC., POMONA, CA 91766

P/N 800-0024

WELCOME JRX-PRO OWNER!!!

Winning races gets harder all the time. As technology and our on track testing advances, so do the cars and trucks that Team Losi produces.

This kit features the latest in racing technology and design as we know it today. We are committed to maintaining the high level of design, construction, ease of use and customer support that has made our cars and customers many time national and international champions. I feel confident you will find this kit to be easy to build and contain all the right parts to be race ready out of the box.

I would like to thank my Dad for not compromising when it came to tooling or the extra costs for the best materials available. Thanks to the Engineering staff for putting up with my demands. Last, but not least, Ron Rossetti and Jack Johnson, you are the best!

Thank you for choosing Team Losi,



Gil Losi Jr.

P.S. Please return the registration card so we can keep you informed of the latest racing tips and technical advancements.

1. INTRODUCTION

The JRX-PRO kit is composed of different bags marked Bag A through Bag F. Each bag contains all of the parts necessary to complete a certain section of the car. It is essential that you open only one bag at a time and follow the right sequence, otherwise you will face difficulties in finding the right part. It is helpful to read the entire instructions for the bag prior to starting assembly. Key numbers (in circles) have been assigned to each part and remain the same in the illustration and throughout the instructions. For your convenience, an actual size hardware identification guide is included in Appendix A of the manual. To check a part, hold it against the silhouette until it is identified. In some cases extra hardware has been supplied to replace easily lost parts. When assembling shafts to plastic parts, different fits e.g., press, net, loose have been designed into the parts. To ensure that parts are not lost during construction, it is suggested that you work over a towel or mat to prevent the parts from rolling away.

IMPORTANT SAFETY NOTES

1. Select an area for assembly that is away from reach of small children. The parts are *small and can be swallowed* by children causing choking and possible internal injuries.
2. The shock fluid supplied should be kept out of children's reach. It is *not toxic* but it was not intended for human consumption.
3. Exercise *care* when using any hand tools, sharp instruments and power tools during construction.
4. Carefully read *all manufacturers warnings and cautions* for any glues or paints that may be used for assembly purposes.

INTRODUCTION (Cont.)

TOOLS REQUIRED

Team Losi has supplied all allen wrenches and a special wrench that is needed for assembly and adjustments. The following common tools will also be required: #2 Phillips screw driver, small flatblade screw driver, needle nose pliers, regular pliers, scissors or other body cutting/trimming tool. 3/16", 1/4", and 3/8" nut drivers are optional.

RADIO/ ELECTRICAL

The JRX-PRO is an out of the box high performance race car. It is for this reason that we have not included specific instructions on radio and electrical equipment installation. We have left this subject to the personal preference of the owner/racer.

A suggested layout is provided in this manual. If you have any further questions, your high performance R/C center will be able to answer any of your questions.

HARDWARE IDENTIFICATION

When in question, use the hardware identification guide in Appendix A. For screws, the prefix number designates the screw size and number threads per inch e.g., 4-40 is a #4 screw with 40 threads per inch. The fraction following designates length of thread or overall if flathead type. Bearings are referenced by inside diameter X outside diameter. Shafts and pins are diameter X length. Washers are described by inside diameter. E-clips are sized by the shaft diameter of attachment.

TABLE OF CONTENTS

1.INTRODUCTION		
Important Safety Notes.....	i	
Tools Required.....	ii	
Hardware.....	ii	
Radio/Electrical.....	ii	
Table of Contents.....	ii	
2.CHASSIS - BAG A		
Chassis Assembly.....	1-3	
Illustration - Chassis.....	4	
3.GEARBOX / DIFFERENTIAL BAG B		
Part 1 Differential Assembly.....	5	
Part 2 Gearbox Assembly.....	6	
Illustration - Exploded Gearbox.....	7	
Part 2 Gearbox Assembly (cont.).....	8	
4.REAR SUSPENSION - BAG C		
Rear Suspension.....	9 -11	
Illustration - Rear Suspension.....	12	
5.FRONT SUSPENSION - BAG D		
Front Suspension.....	13 -14	
Illustration - Front Suspension.....	15	
6.SHOCKS - BAG E		
Shock Assembly.....	16	
Illustration - Shock Assembly.....	17	
Shock Attachment.....	18	
7.WHEELS & TIRES - BAG F		
Assembly and Attachment.....	19	
8.FINAL ASSEMBLY		
Motor, Antenna, Body Painting.....	20	
Body, Gear Cover, Wing.....	21	
Wing Buttons.....	22	
9.ELECTRICAL/ELECTRONIC		
Suggested Layout.....	23	
10.TUNING TIPS.....	24- 26	
11.TOE IN / TOE OUT & CAMBER ...	27	
12.APPENDIX A		
Hardware ID Guide.....	28-29	
13.SPARE PARTS LIST.....	30-32	
14. MAINTENANCE SCHEDULE.....	33	

BAG A CHASSIS ASSEMBLY

1. Affix aluminum steering posts (4) to chassis (2) using two 4-40 x 3/8" flathead screws (3). Fig. 1.

2. Insert wing tubes (68) into rear bulkhead (6). Fig. 2.

* NOTE: Wing tubes are a tight press fit. . Fig. 2.

3. Secure rear shock tower (5) and shock tower spacer (65) to rear bulkhead (6) using two 4-40 x 1/2" flat head screws (104) in the upper holes and two 4-40 x 1/2" socket head screws (36) in the lower holes. Fig. 2.

4. Connect rear bulkhead (6) to chassis (2) using two 8-32 x 1/2" flathead aluminum screws (8) in the rear, and two 4-40 x 3/8" flathead screws (3) in the front. Fig. 2.

* NOTE: Use caution when screwing in aluminum screws as the heads may strip. Fig. 2.

5. Install 3/8" studded ball joints (55) from the rear into bottom inside holes in rear bulkhead (6). Fig. 2

6. Attach shockmounts (56) to back of rear shocktower (5) in top inside holes using 4-40 x 7/8" socket head screws (57). Fig. 2.

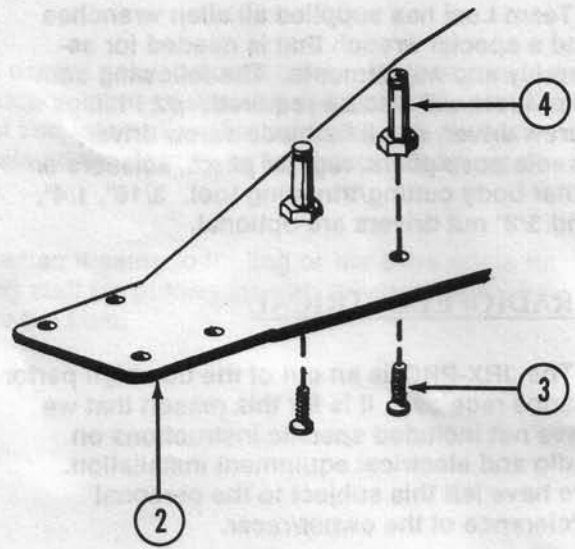

FIG. 1

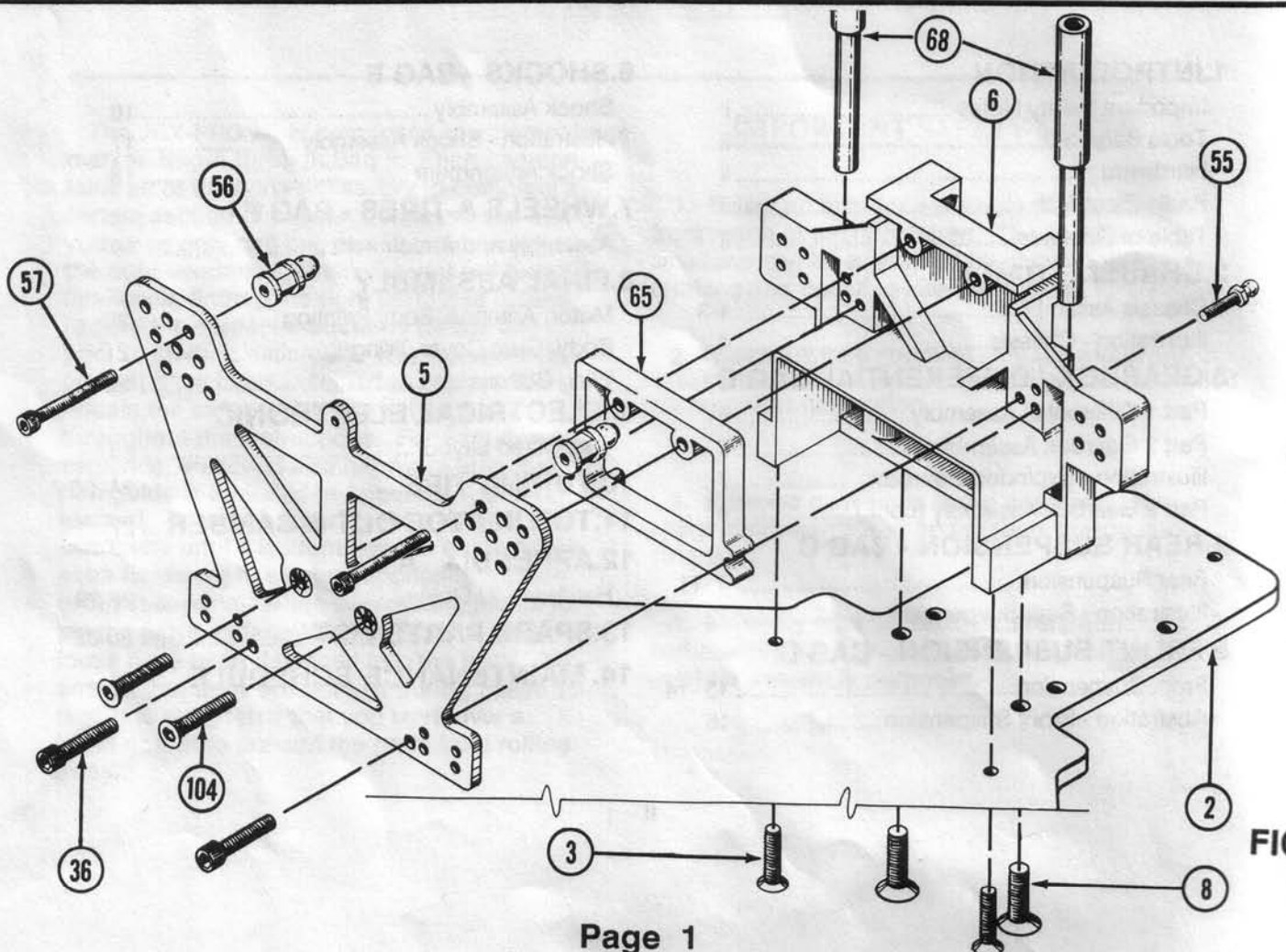

FIG. 2

BAG A (Cont.) CHASSIS ASSEMBLY

7. Attach shock mounts (56) to front shock tower (9) in top outside holes using two 4-40 x 7/8" socket head screws (57). Fig. 3.

8. Fasten 3/16" studded ball joints (72) to opposite side of front shock tower (9) in the center of the three lower outside holes and secure with 4-40 nuts (117). Fig.3.

9. Secure front shock tower (9) to front bulkhead (10) using two 4 -40 x 3/8" socket head screws (7). Fig. 3.

* *NOTE: Shock mounts should face foward. Studded-ball joints should face rearward. Middle hole is suggested for initial setup.*

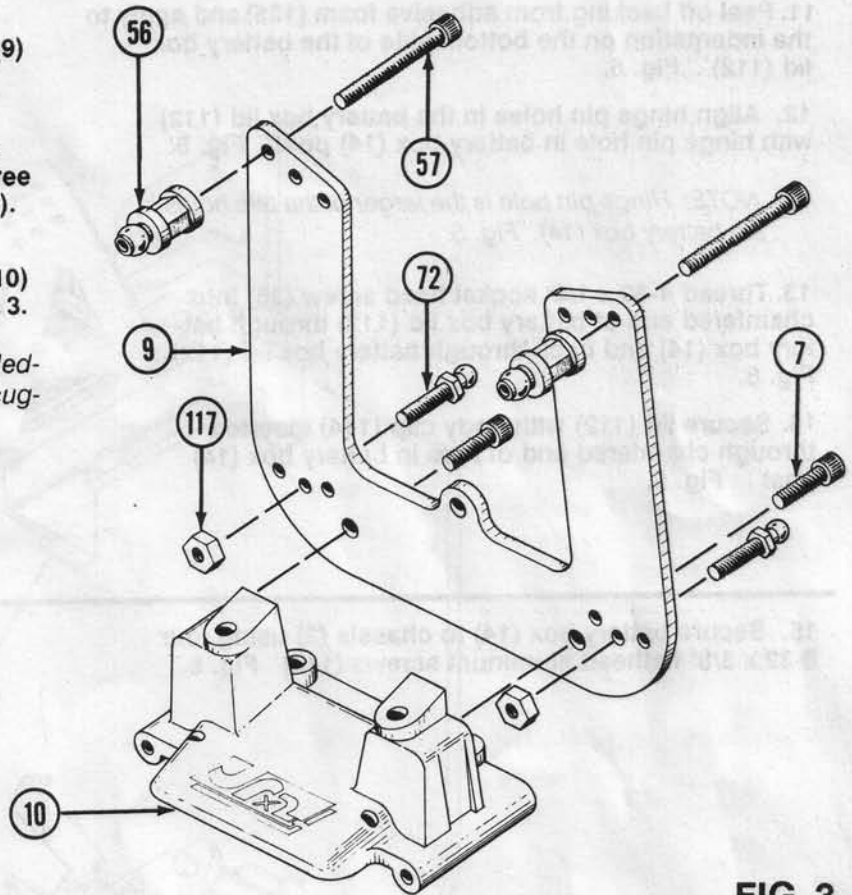

FIG. 3

10. Assemble both front bulkhead (10) and bumper (69) simultaneously to front of chassis (2) using four 8-32 x 1/2" flathead aluminum screws (8). Fig. 4.

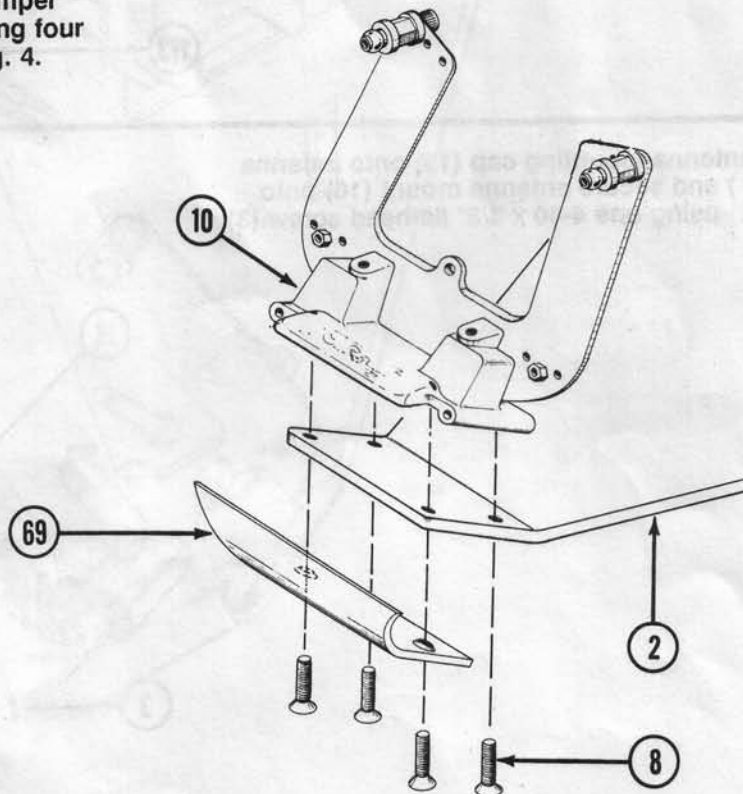

FIG. 4

BAG A (Cont.) CHASSIS ASSEMBLY

11. Peel off backing from adhesive foam (125) and apply to the indentation on the bottom side of the battery box lid (112) . Fig. 5.

12. Align hinge pin holes in the battery box lid (112) with hinge pin hole in battery box (14) post. Fig. 5.

* NOTE: Hinge pin hole is the larger of the two holes in the battery box (14). Fig. 5.

13. Thread 4-40 x 1/2" socket head screw (36) into chamfered end of battery box lid (112) through battery box (14) and back through battery box lid (112). Fig. 5.

14. Secure lid (112) with body clip (114) inserted through chamfered end of hole in battery box (14) post . Fig. 5.

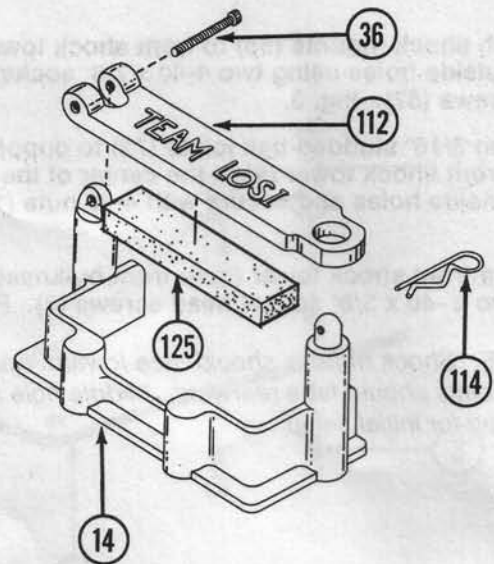

FIG. 5

15. Secure battery box (14) to chassis (2) using four 8-32 x 3/8" flathead aluminum screws (113) Fig. 6.

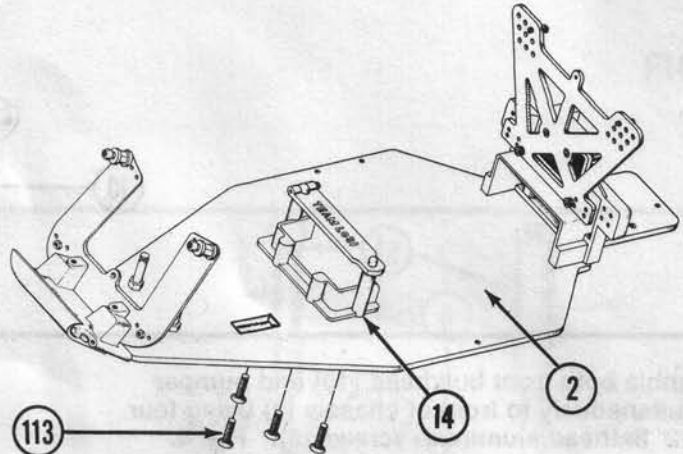

FIG. 6

16. Snap antenna mounting cap (15) onto antenna mount (16) and secure antenna mount (16) onto chassis (2) using one 4-40 x 3/8" flathead screw (3). Fig. 7.

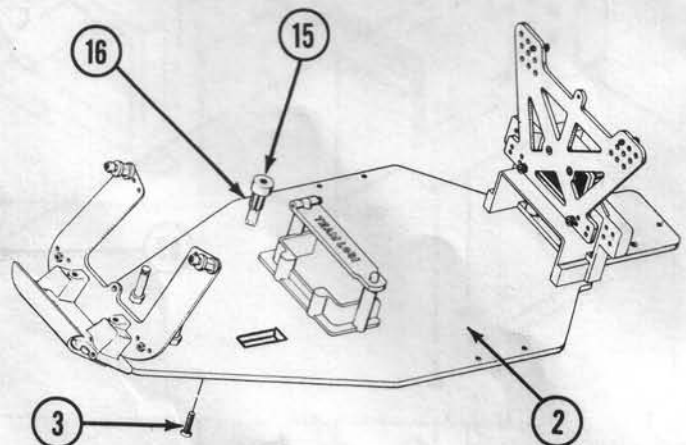
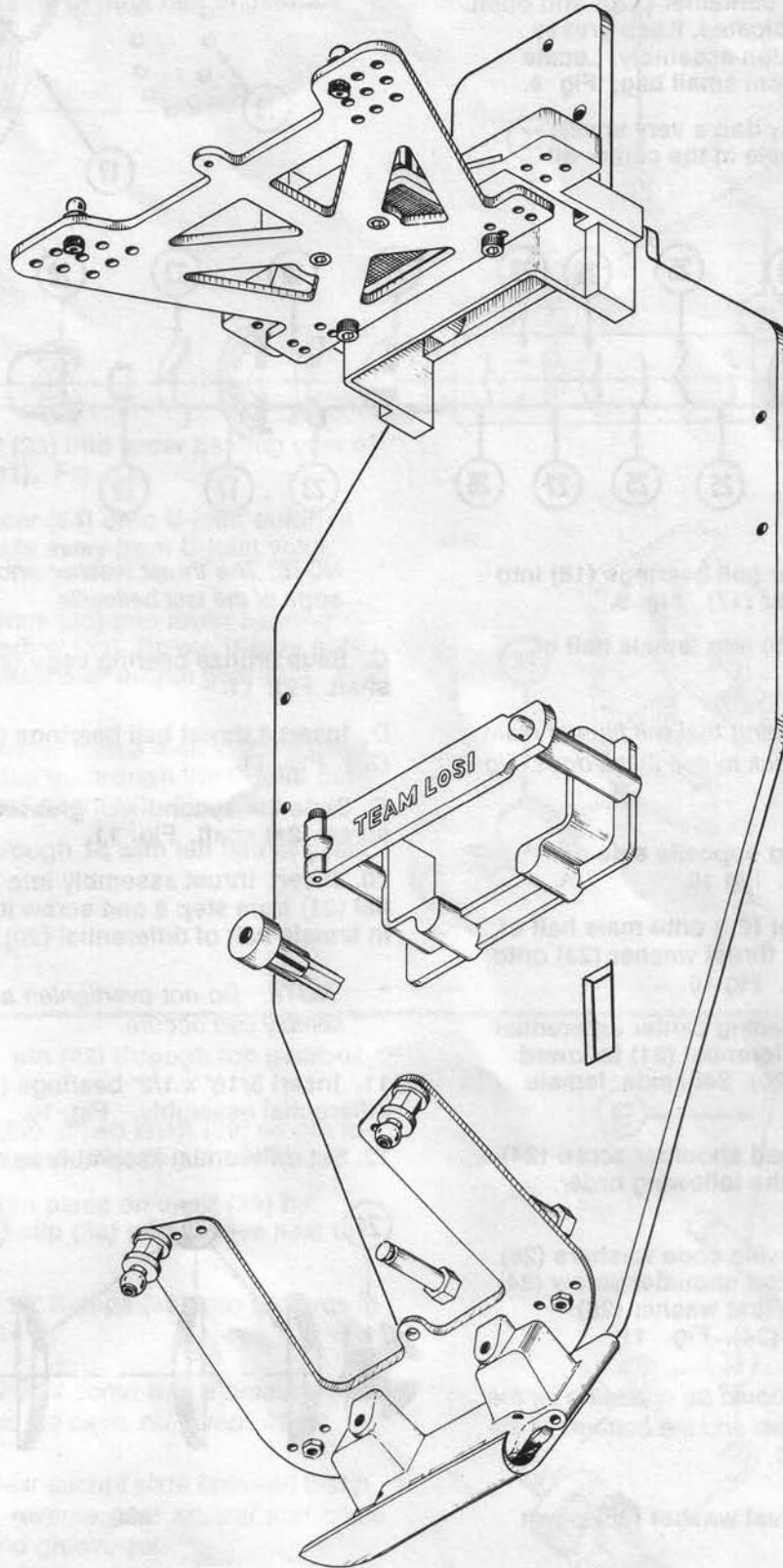

FIG. 7

BAG A COMPLETE CHASSIS



BAG B DIFFERENTIAL ASSEMBLY

1. Locate and open Bag B. Remove small inner bag containing differential parts and set remainder of parts aside for now.

2. Locate small white grease container (120) and open. Grease only items that are indicated. Keep grease away from teeth of transmission assembly. Locate center differential gear (17) from small bag. Fig 9.

3. Using a tooth pick, carefully dab a very small amount of grease into each hole in the center differential gear (17). Fig 9.

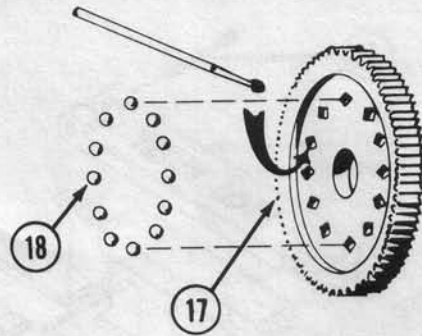

FIG. 9

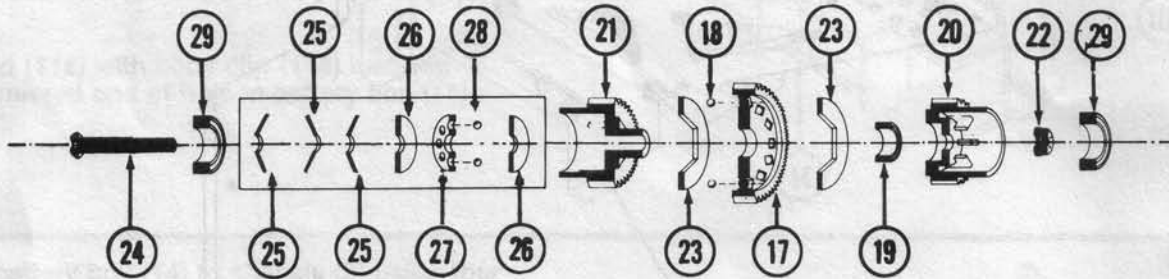

FIG. 10

4. Insert 3/32" differential gear ball bearings (18) into holes in center differential gear (17). Fig 9.

5. Insert 1/4" x 3/8" bearing (19) into female half of differential (20). Fig. 10.

* NOTE: This is the only bearing that will fit over male half of differential (21). Check to see that it does. Fig 10.

6. Insert 5-40 locknut (22) into opposite side of female half of differential (20). Fig 10.

7. Place one hex thrust washer (23) onto male half of differential (21) and other hex thrust washer (23) onto female half of differential (20). Fig 10.

8. Assemble differential by placing center differential gear (17) onto male half of differential (21) followed by female half of differential (20). Set aside. female half up, until step 10. Fig 10.

9. Using 5-40 x 7/8" button head shoulder screw (24) assemble thrust assembly in the following order. Fig. 10.

A. Slide three opposing belleville cone washers (25) down the 5-40 x 7/8" button head shoulder screw (24) with the top of the cone of the first washer (25) against the head of the screw (24). Fig. 11.

* NOTE: The washers (25) should be opposing ie; the tops of the cones should meet and the bottoms of the cones should meet. Fig. 11.

B. Slide one well greased thrust washer (26) down screw (24) shaft. Fig. 11.

* NOTE: The thrust washer should only touch the big edge of the last belleville.

C. Slide bronze bearing cage (27) down screw (24) shaft. Fig. 11.

D. Insert 8 thrust ball bearings (28) into the cage (27). Fig. 11.

E. Slide the second well greased washer (26) down screw (24) shaft. Fig. 11.

10. Insert thrust assembly into male half of differential (21) from step 8 and screw into 5-40 locknut (22) in female half of differential (20). Fig.10.

* NOTE: Do not overtighten as damage to thrust assembly can occur.

11. Insert 5/16" x 1/2" bearings (29) into both sides of differential assembly. Fig. 10.

12. Set differential assembly aside until step 25.

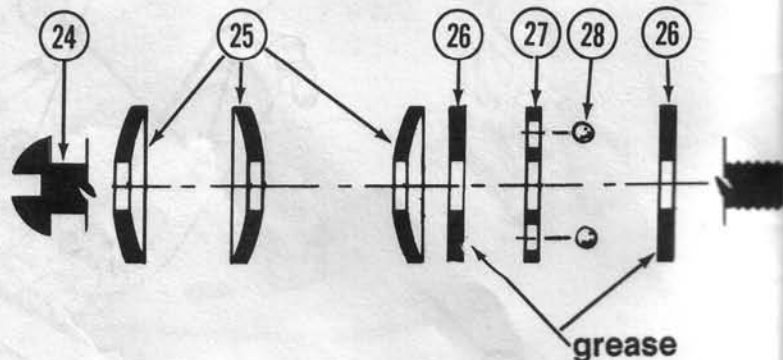

FIG. 11

BAG B (Cont.) GEARBOX ASSEMBLY

13. Insert 3/16" x 3/8" bearing (30) into upper bearing seat of right half of gearbox (31). Fig. 12.

14. Insert two 8mm x 14mm bearings (32) into both sides of lower bearing seat of right half of gearbox (31). Fig. 12.

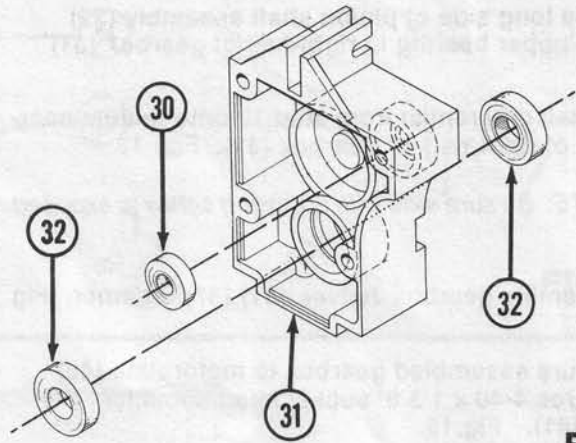

FIG. 12

15. Install output gear (33) into lower bearing seat of right half of gearbox (31). Fig. 13.

16. Slide outride spacer (34) onto U-joint outride (35) with the flanged side away from U-joint yoke. Fig. 13.

17. Install U-joint outride (35) into lower bearing seat of right half of gearbox (31). Rotate U-joint outride (35) until interlocked with output gear (33). Fig. 13.

18. Secure the two together with a 4-40 x 1/2" socket head screw (36) threaded in through the U-joint outride (35) into the output gear (33). Fig. 13.

19. Repeat steps 13 through 18 with left half of gearbox (37).

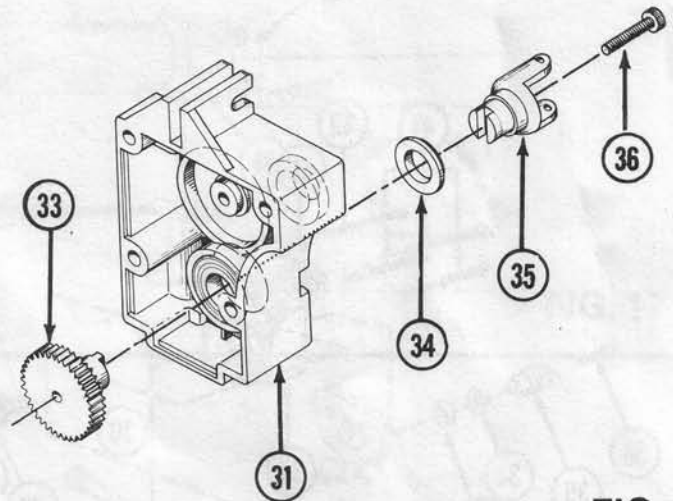

FIG. 13

20. Push 1/16" x 7/16" pin (42) through top gearbox shaft (39). Fig. 14 A.

21. Slide pinion gear (90) down shaft (39) so pin interlocks with groove in gear (90). Fig. 14 A.

22. Lock pinion (90) into place on shaft (39) by snapping a large 3/16" E-clip (38) into groove next to pinion (90). Fig. 14 A.

23. Install two large 3/16" E-clips (38) into grooves in pinion shaft (39). Fig. 14 B.

* *NOTE: Some kits might come with a preassembled pinion shaft. If this is the case, skip steps 20-22.*

* *NOTE: Make sure gear cannot slide between E-clip and pin. If it does, reverse gear around and place between other pin and groove set.*

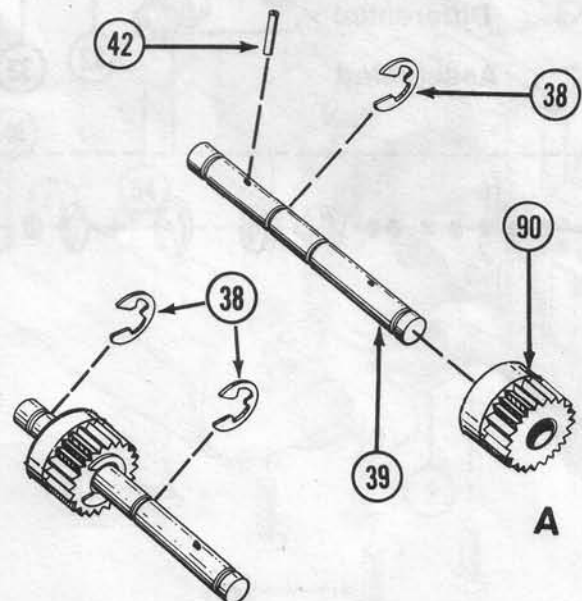

A

B

BAG B MAJOR GEARBOX ASSEMBLY

24. Slide long side of pinion shaft assembly (39) through upper bearing in right half of gearbox (31) Fig. 15.

25. Install differential from step 12 onto middle bearing seat of right half of gearbox (31). Fig. 15

* NOTE: Be sure side with adjusting screw is exposed.

26. Assemble gearbox halves (31) (37) together. Fig. 15.

27. Secure assembled gearbox to motorplate (40) using three 4-40 x 1 3/8" socket head shoulder screws (41). Fig.15.

* NOTE: Do not use upper forward hole at this time.

28. Insert 1/16" x 7/16" spiral pin (42) into pinion shaft (39) assembly. Press spur gear (43) down onto pinion shaft (39) assembly being sure to align groove in spur gear (43) with pin (42) in shaft (39). Secure gear (43) onto shaft (39) with one large 3/16" E-clip (38) in groove in end of shaft (39). Fig. 15.

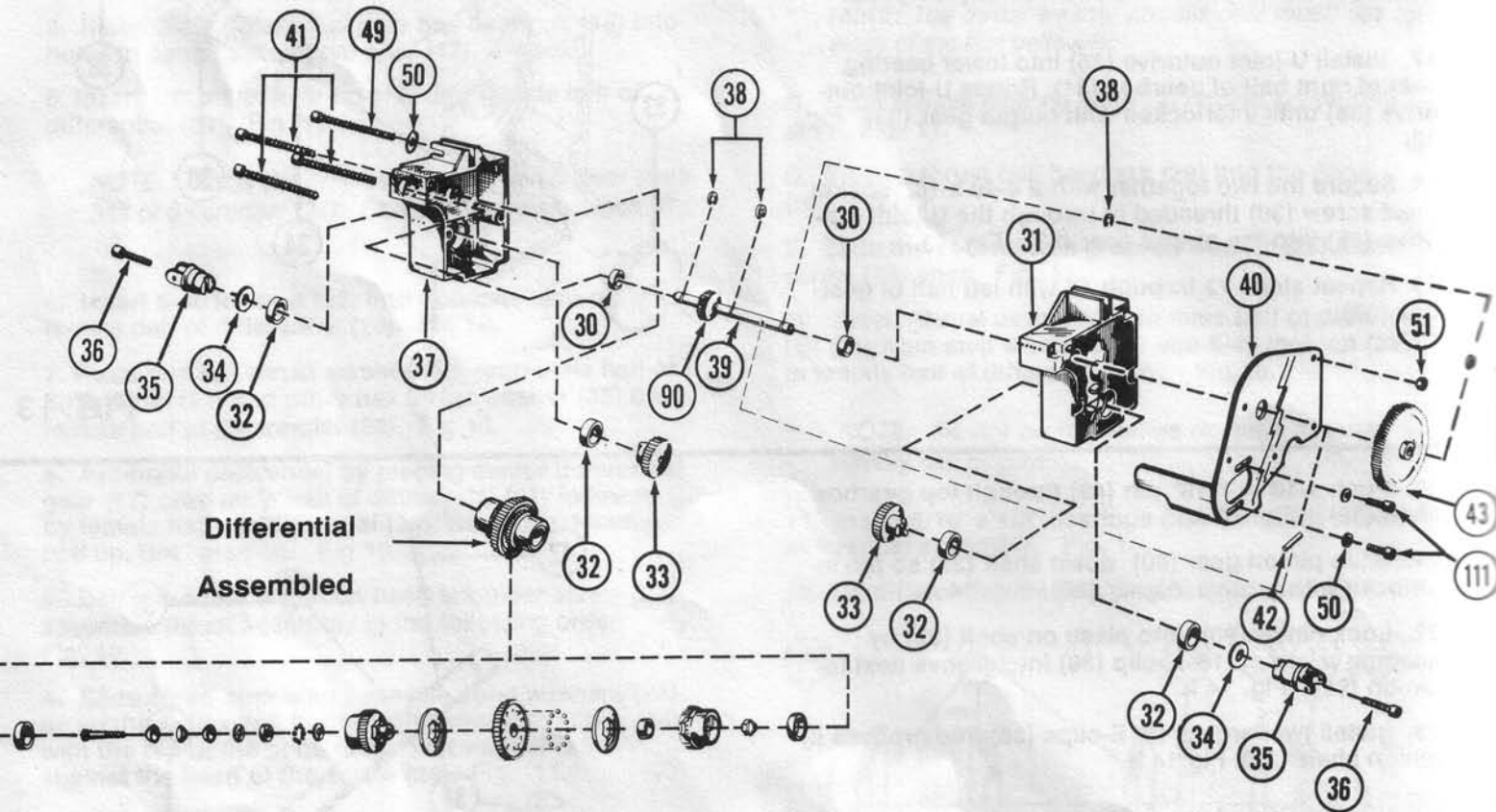

BAG B (Cont.) GEARBOX ASSEMBLY

29. Insert $3/32"$ x $1/2"$ spirol pin (44) into universal pivot joint (45) so that it extends out evenly on both sides. Fig. 16.

* NOTE: Assemble two only.

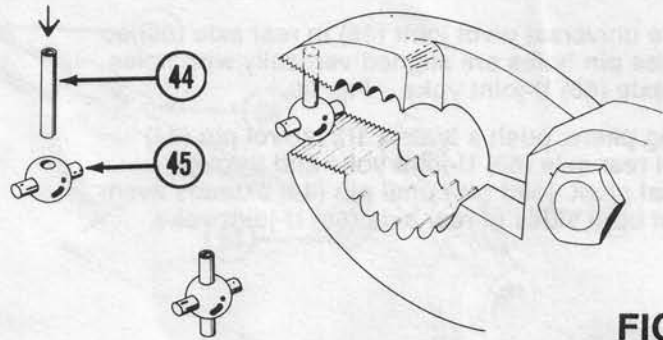

FIG. 16

30. Wedge one end of $3/32"$ x $1/2"$ spirol pin (44) in universal pivot joint (45) into female drive shaft (46) U-joint yoke. Fig. 17.

31. Using rounded end of TEAM LOSI wrench supplied with kit, pry opposite end of $3/32"$ x $1/2"$ spirol pin (44) into other side of female drive shaft (46) U-joint yoke. Fig. 17.

* NOTE: It might take some force so be patient.

32. Using remaining pins in universal pivot joint (45), repeat steps 30 and 31 to secure the same universal pivot joint (45) to right hand U-joint outdrive (35). Fig. 17.

33. Repeat steps 29-32 for other side of car.

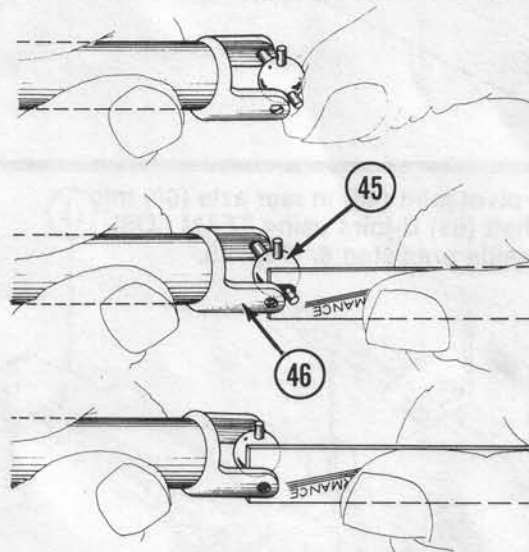

FIG. 17

34. While holding rear pivot support (47) in place under rear of gearbox, slide gearbox into place in rear bulkhead (6). Fig. 18.

* NOTE: Use pivot support #1 for initial setting.

35. Secure gearbox and rear pivot support (47) to chassis (2) using four 8-32 x $1/2"$ steel flathead screws (115). Fig. 18.

* NOTE: Refer to tuning tips for rear pivot support selection. Steel screws are grey color.

36. Secure motorplate (40) to chassis (2) using a 4-40 x $1/4"$ flathead screws (48). Fig. 18.

37. Secure gearbox to rear bulkhead (6) using a 4-40 x $1\ 3/4"$ socket head screw (49) with a #4 washer (50) under the head. Fig. 18.

* NOTE: The 4-40 nylon nut (51) and the 4-40 x $1/8"$ button head screw (52) will be used later to screw the gear cover (107).

38. Push dust cover (54) over differential adjustment hole in gearbox. Fig. 18.

* NOTE: Motor screws (111) are supplied, put them aside until its time to mount your motor.

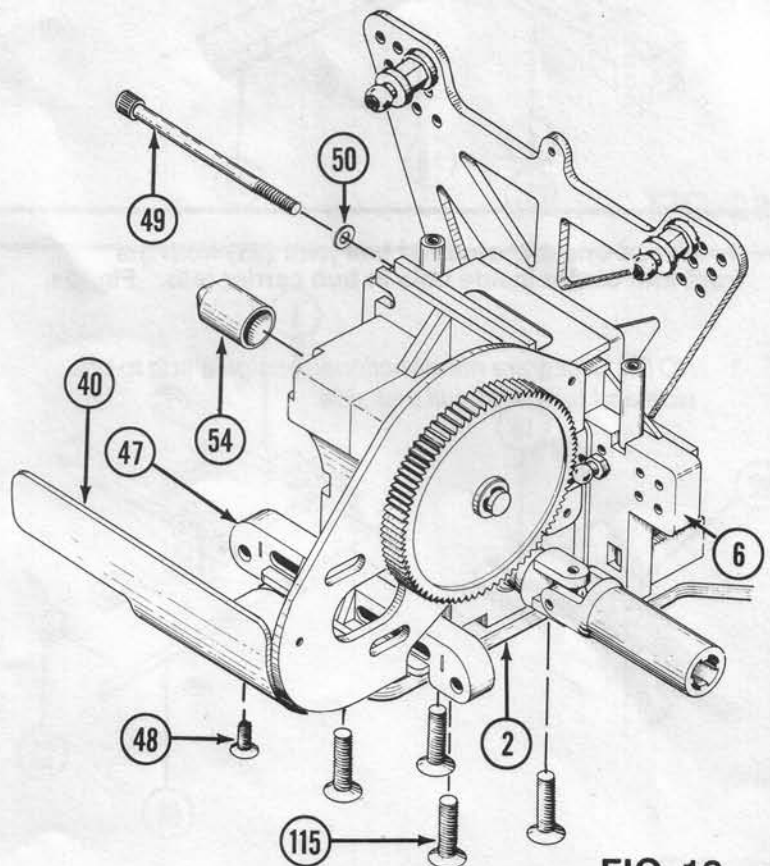

FIG. 18

BAG C REAR SUSPENSION

1 Place universal pivot joint (45) in rear axle (60) so that cross pin holes are aligned vertically with holes in rear axle (60) U-joint yoke. Fig. 20.

2. Using pliers, push a 3/32" x 1/2" spirol pin (44) through rear axle (60) U-joint yoke and through universal pivot joint (45) until pin (44) extends evenly out of both sides of rear axle (60) U-joint yoke. Fig. 20.

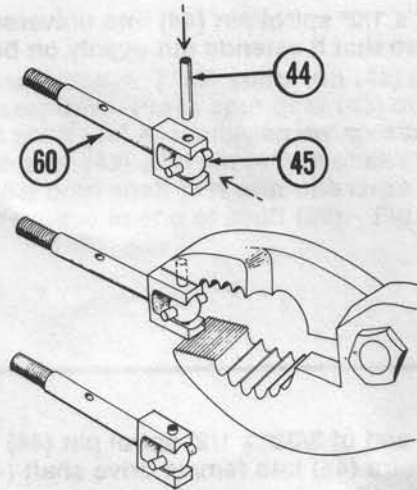

FIG. 19

3. Pry universal pivot joint (45) in rear axle (60) into the male drive shaft (61) U-joint using TEAM LOSI wrench and set aside until step 6. Fig. 20.

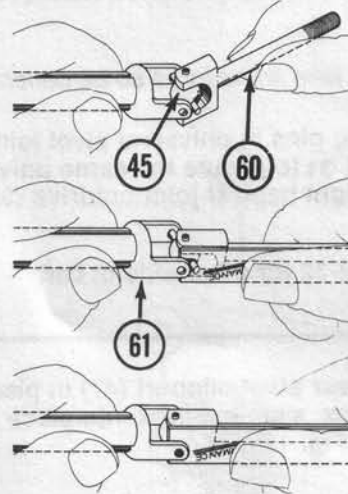

FIG. 20

4. Thread one 3/8" studded ball joint (55) from the front into center inside hole in hub carrier (59). Fig. 21.

* NOTE: Hubs are nondirectional; assign a hub to one side and build it to suit that side.

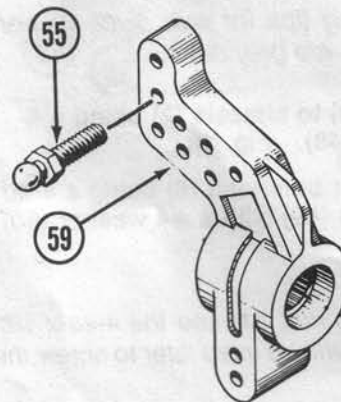

FIG. 21

BAG C (Cont.) REAR SUSPENSION

5. Press two 3/16" x 3/8" bearings (30) into both sides of hub carrier (59). Fig. 22.
6. Slide rear axle (60) from step 3, through hub carrier (59). Fig. 22.
7. Slide spacer washer (67) down axle (60) towards hub carrier (59) and secure to axle (60) by inserting 1/16" x 7/16" solid pin (62) into hole in rear axle (60). Fig. 22.
8. Repeat 1 to 7 for other side. Set hub carrier assemblies aside until step 13.

* *NOTE: The H-arms have a letter and an arrow on the bottom. The letter is for Left and Right, and the arrow points to the front of the car. The spacers on the H-arm will be used in Bag E. Set them aside until then.*

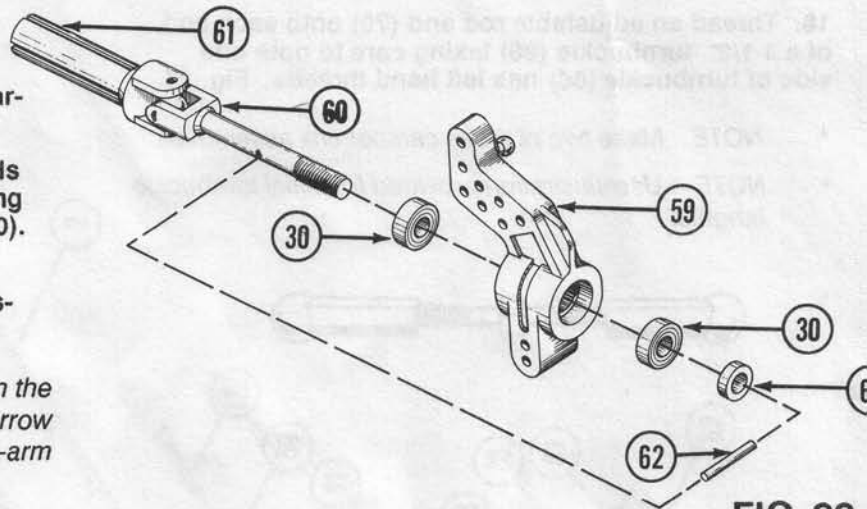

FIG. 22

9. Align the H-arm [(Right (1), Left (123))] as shown between the rear pivot support (47) and rear bulkhead (6). Fig. 23.

10. Insert 1/8" x 1.785 hinge pin (63) through rear pivot support (47) and H-arm (1) (123) until forward E-clip groove is located half way between rails of H-arm (1)(123). Fig. 23.

11. Place 1/8" E-clip (64) in forward groove in pin (63) and push pin through forward rail of H-arm (1) (123) and into bulkhead (6). Fig. 23.

12. Secure H-arm (1) (123) with 1/8" E-clip (64) in rear groove in pin (63). Fig. 23.

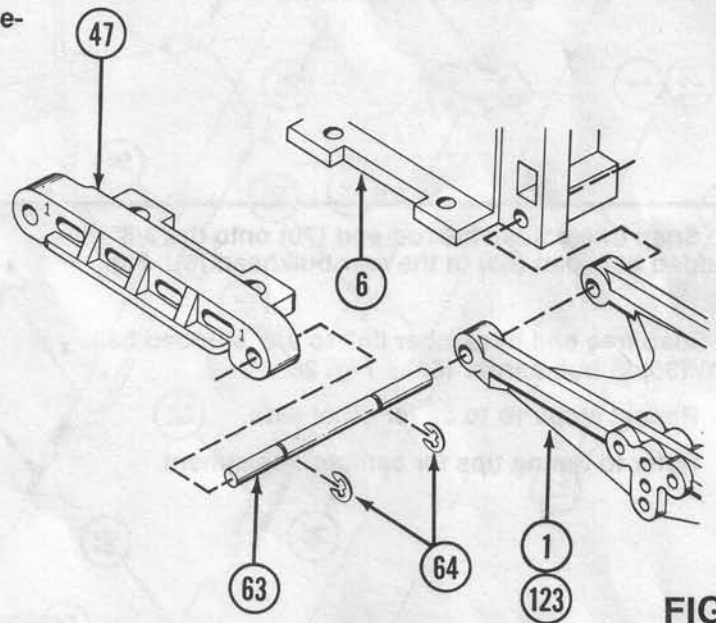

FIG. 23

13. Place hub carrier assembly between the outer rails of the H-arm (1) (123) as shown Fig. 24.

14. Insert 1/8" x 1.420 hinge pin (66) through H-arm (1) (128) and hub carrier (59). Fig. 24

15. Secure pin (66) by placing two snap clips (12) in grooves on either side of hub carrier (59). Fig. 24.

* *NOTE: Its easiest if one groove in pin is given excess room for clip, then push hub carrier up against it and snap in second clip.*

16. Hold chassis (2) level and let hub carrier assembly dangle. Align the splines in the drive shaft halves (46) (61) and insert male half (61) into female half (46). Swing hub carrier assembly back up to level with chassis (2) and check for freedom of travel. Fig. 24.

17. Repeat steps 9 to 16 for other side of car.

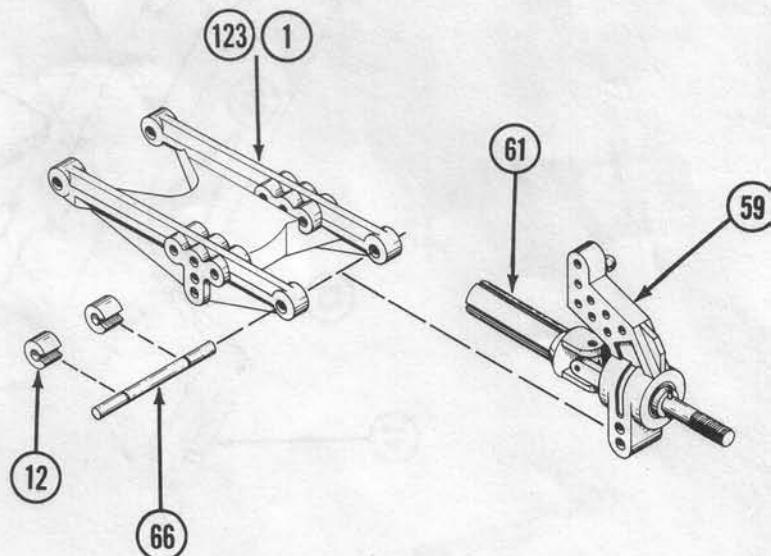
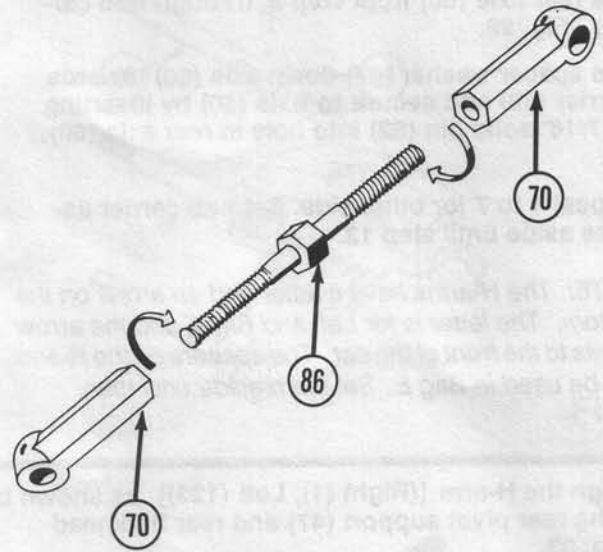
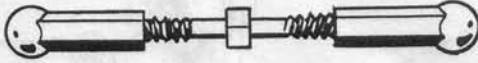

FIG. 24

BAG C (Cont.) REAR SUSPENSION

18. Thread an adjustable rod end (70) onto each end of a 1 1/2" turnbuckle (86) taking care to note one side of turnbuckle (86) has left hand threads. Fig. 25.

- * NOTE Make two of these camber link assemblies.
- * NOTE Use illustration provided for initial turnbuckle lengths.



19. Snap one adjustable rod end (70) onto the 3/8" studded ball joint (55) in the rear bulkhead (6). Fig. 26.

20. Snap free end of camber link to 3/8" studded ball joint (55) in hub carrier (59). Fig. 26.

21. Repeat steps 19 to 20 for other side.

24. Refer to tuning tips for camber adjustment.

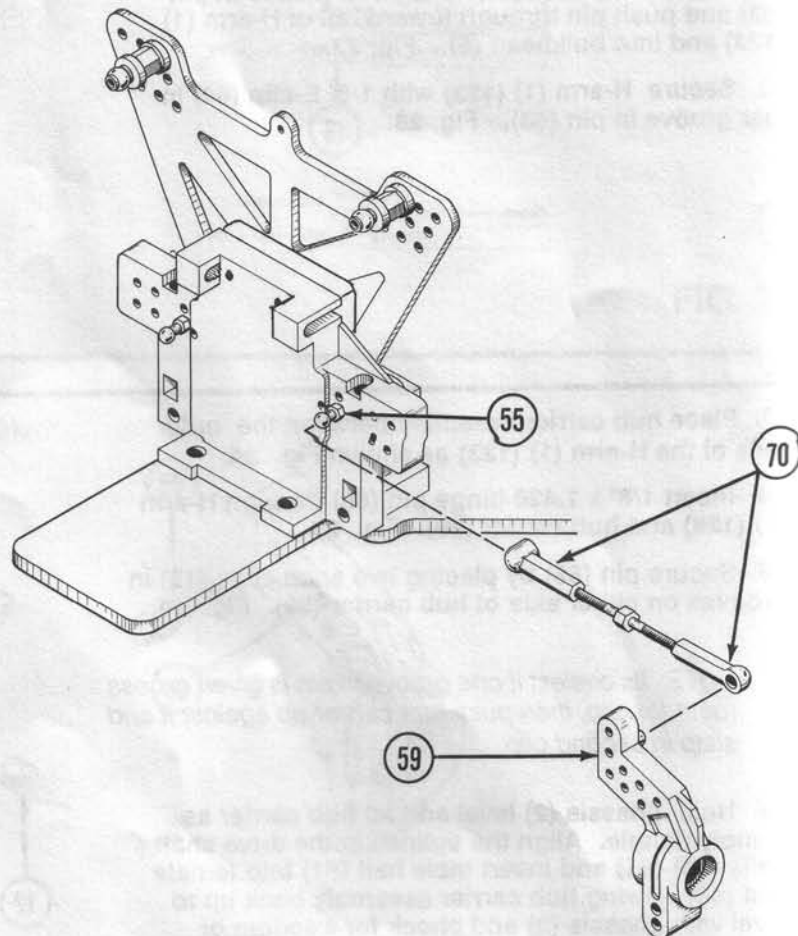

BAG C EXPLODED REAR SUSPENSION

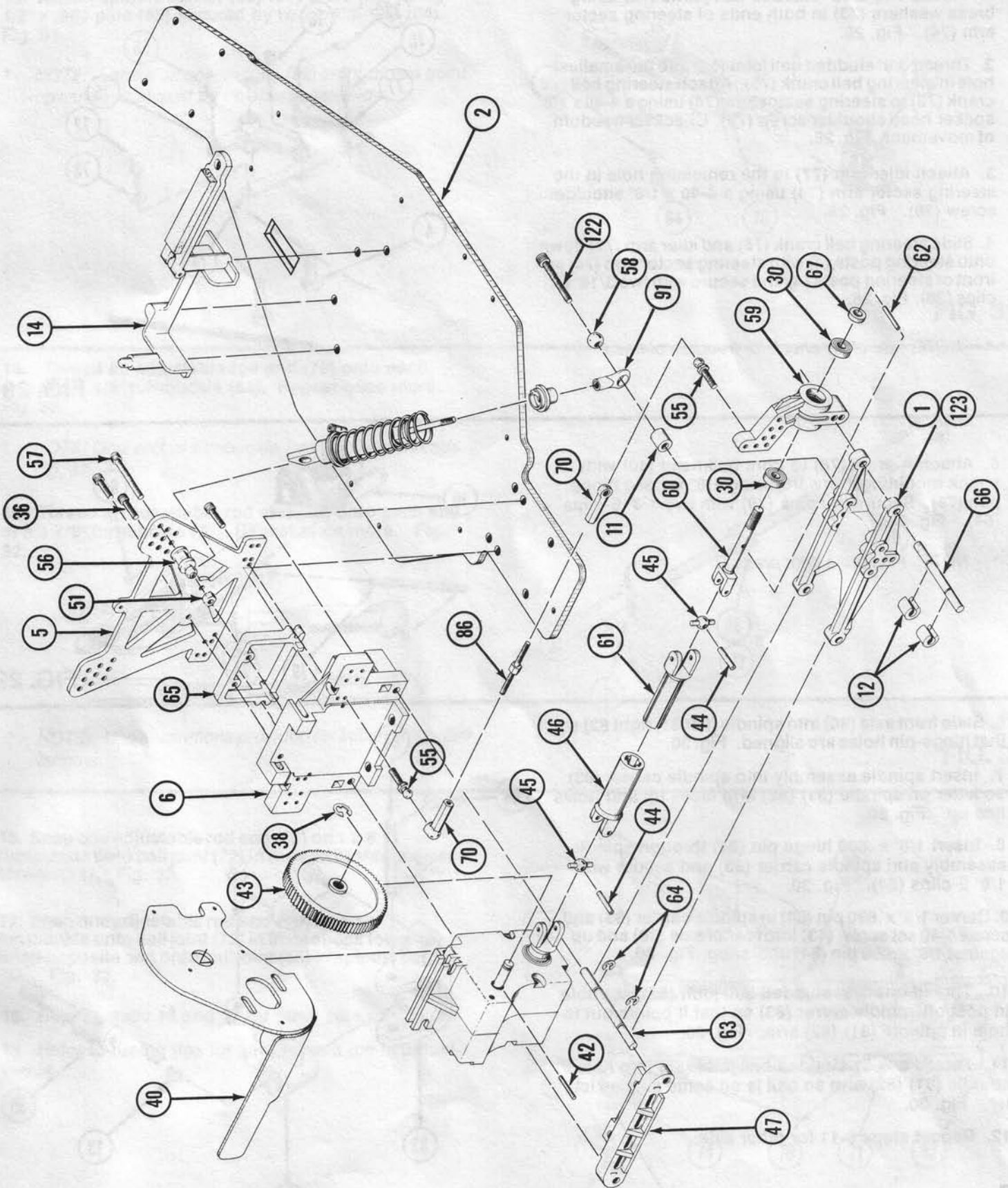

BAG D FRONT SUSPENSION

1. Thread two 3/16" studded ball joints (72) using brass washers (73) in both ends of steering sector arm (74). Fig. 28.
2. Thread 3/8" studded ball joint (55) into the smallest hole in steering bell crank (75). Attach steering bell crank (75) to steering sector arm (74) using a 4-40 x 1/8" socket head shoulder screw (76). Check for freedom of movement. Fig. 28.
3. Attach idler arm (77) to the remaining hole in the steering sector arm (74) using a 4-40 x 1/8" shoulder screw (76). Fig. 28.
4. Slide steering bell crank (75) and idler arm (77) down onto steering posts (4) with steering sector arm (74) in front of steering posts (4) and secure with two 3/16" E-clips (38). Fig. 28.

* NOTE: Carefully check for freedom of travel.

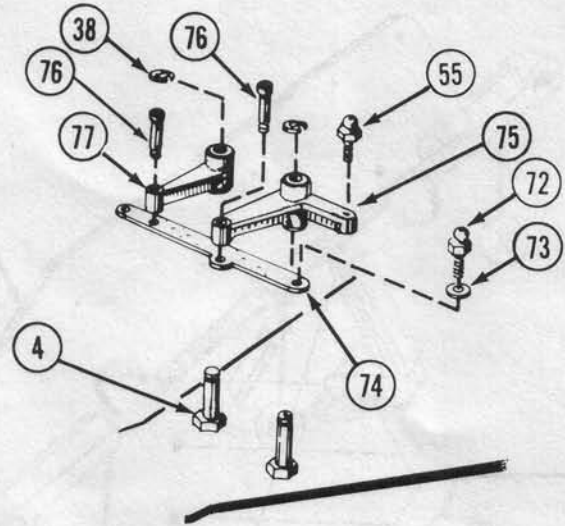

FIG. 28

5. Attach A-arms (78) to front bulkhead (10) with shock mountings forward using 1/8" x 1.650 hinge pins (79). Secure the pins (79) with two 1/8" E-clips (64). Fig. 29.

* NOTE: Pins are a tight press fit.

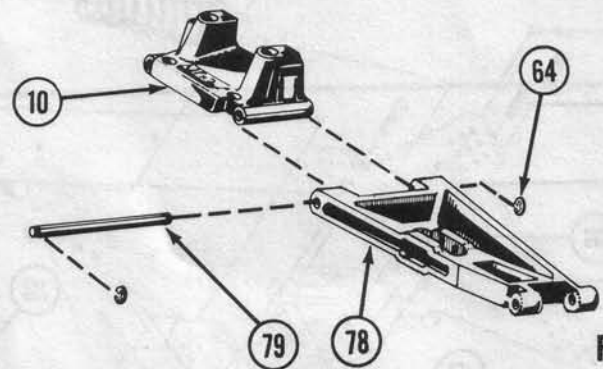

FIG. 29

6. Slide front axle (80) into spindle (left 81, right 82) so that hinge-pin holes are aligned. Fig. 30.
7. Insert spindle assembly into spindle carrier (83) so letter on spindle (81) (82) arm faces up and holes line up. Fig. 30.
8. Insert 1/8" x .690 hinge pin (84) through spindle assembly and spindle carrier (83) and secure with 1/8" E-clips (64). Fig. 30.
9. Center 1/8" x .690 pin (84) in spindle carrier (83) and screw 5-40 set screw (13) into rear of axle (80) and up against 1/8" x .690 pin (84) until snug. Fig. 30.
10. Thread one 3/8" studded ball joint (55) into hole in post on spindle carrier (83) so that it points out to hole in spindle (81) (82) arm. Fig. 30.
11. Thread a 3/8" studded ball joint (55) into hole in spindle (81) (82) arm so ball is on same side as letter. Fig. 30.
12. Repeat steps 6-11 for other side.

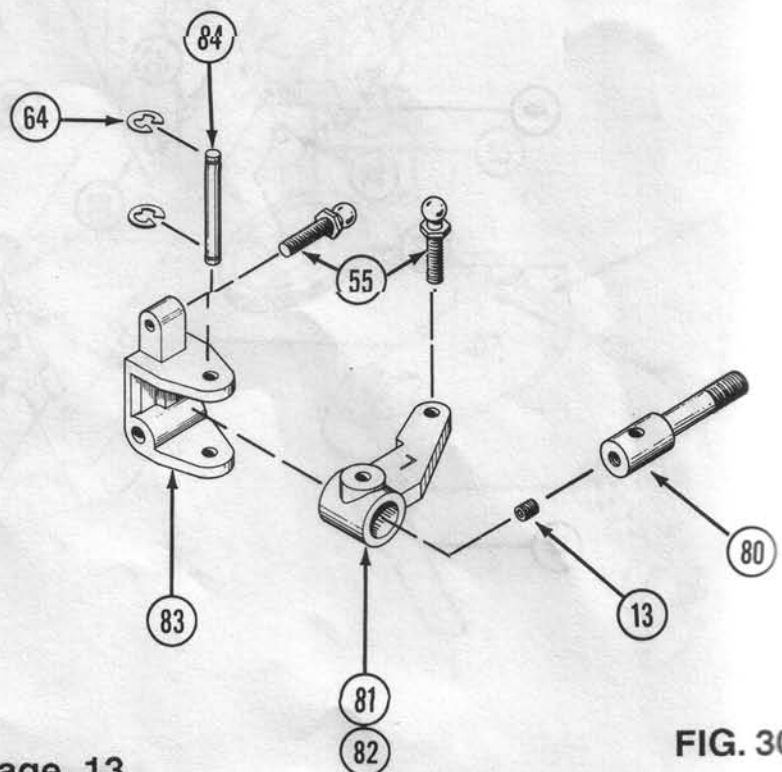

FIG. 30

13. Attach spindle carrier (83) to A-arms (78) using 1/8" x .960 pins (85) secured by two 1/8" E-clip (64). Fig. 31.

* NOTE: Letters on spindle (81) (82) arms should point upward and should be on appropriate side.

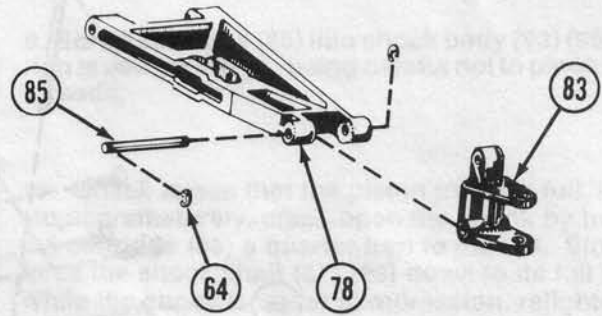
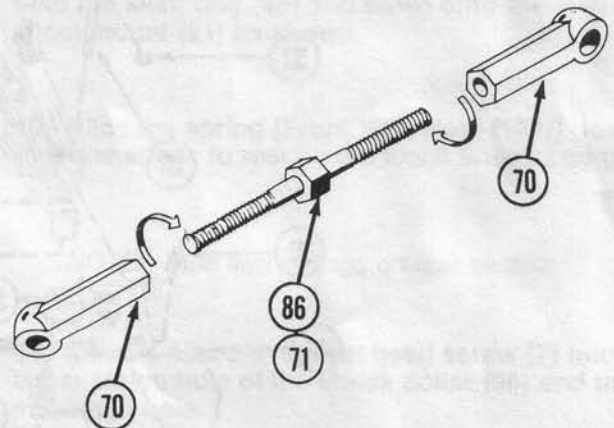
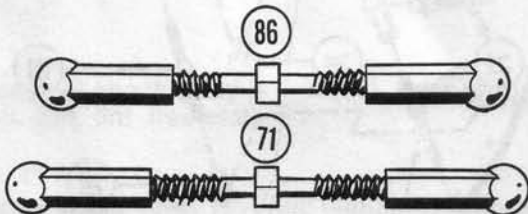

FIG. 31

14. Thread an adjustable rod end (70) onto each end of a 1 1/2" turnbuckle (86). Repeat once more. Fig. 32.

* NOTE: One end of turnbuckle has left hand threads. Fig. 37

15. Thread an adjustable rod end (70) onto each end of a 1 7/8" turnbuckle (71). Repeat once more. Fig. 32.



* NOTE: Use illustrations provided for initial turnbuckle lengths.

FIG. 32

16. Snap one adjustable rod end (70) on 1 7/8 turnbuckle onto ball joint (72) in the end of steering sector arm (74). Fig. 33.

17. Snap one adjustable rod end (70) on 1 1/2" turnbuckle onto ball joint (72) in front shock tower (9). Snap opposite end onto ball joint (55) in spindle carrier (83). Fig. 33.

18. Repeat steps 16 and 17 for other side.

19. Refer to tuning tips for camber and toe in adjustments.

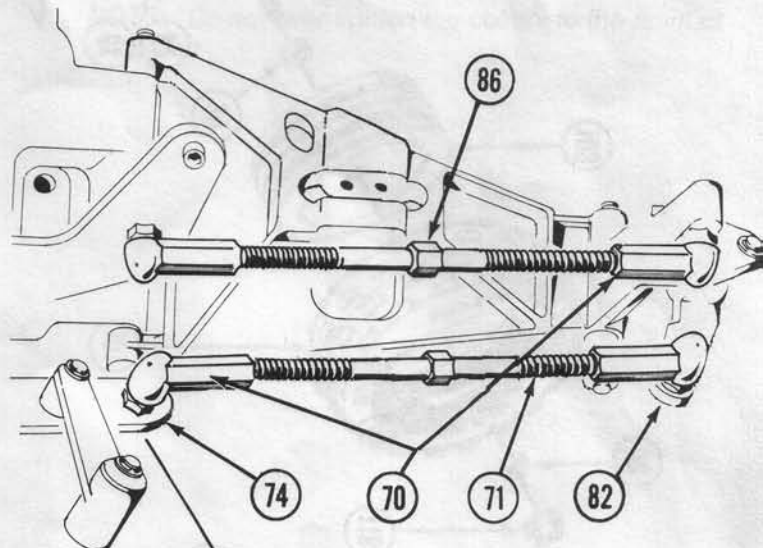

FIG. 33

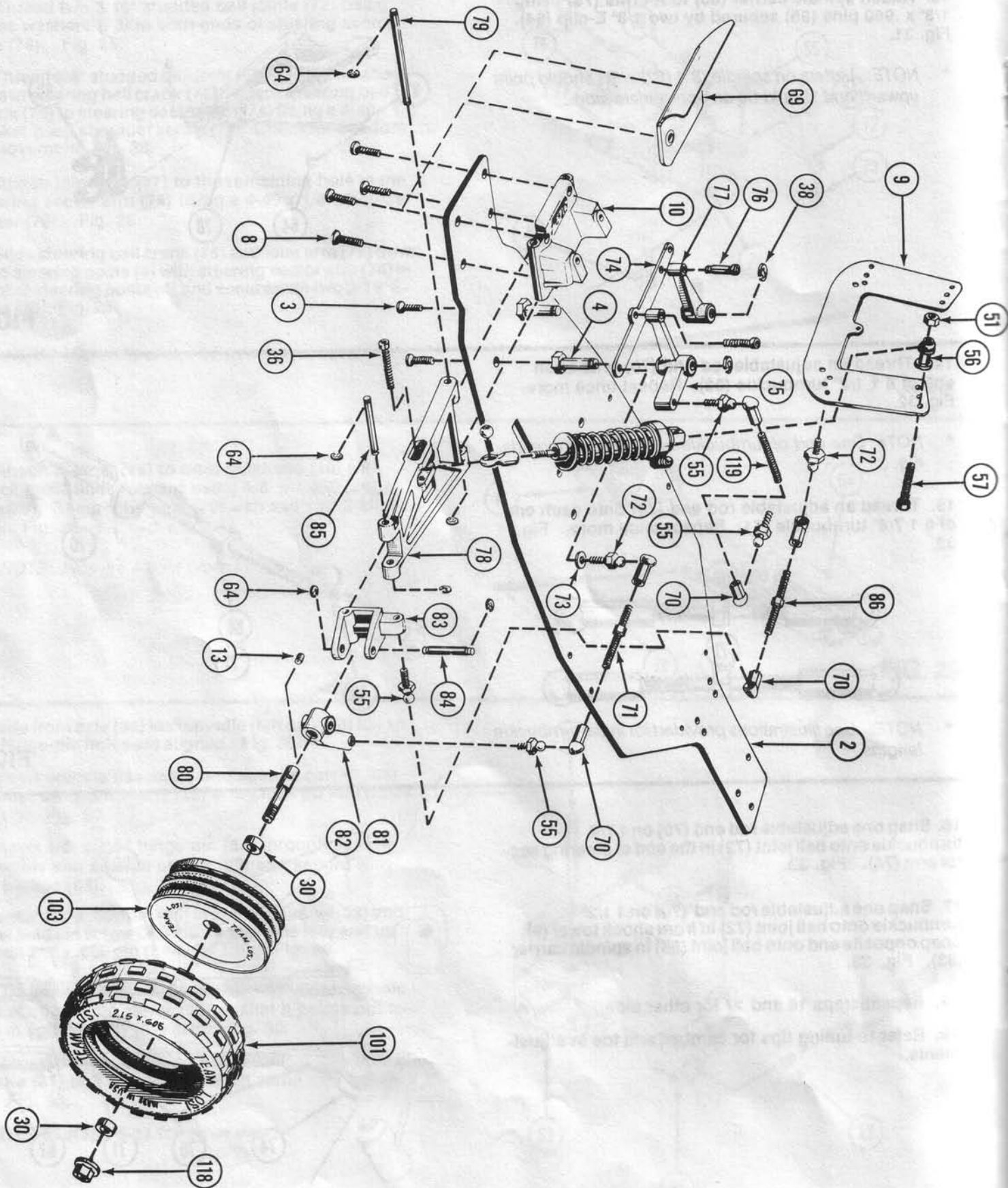

FIG. 34

BAG E SHOCK ASSEMBLY

1. Place a drop of oil on grooved end of shock shaft (87) (99) and slide cartridge (88), hex end first, down shock shaft [Front (87), Rear (99)] towards the threads.

* *NOTE: Be sure the external O-ring (89) is in the groove on the cartridge.*

2. Grasp the shock shaft [Front (87), Rear (99)] between the grooves in the end with a pair of needle nose pliers and thread on the shock mounts (91).

3. Snap 1/8" E-clip (64) into the groove closest to the threads in the shock shaft (87) (99).

4. Clean sprue off of piston (92) and slide piston (92) onto shaft (87) (99) from grooved end until it rests against the E-clip (64).

5. Secure piston (92) in place with another E-clip (64).

6. Clean out shock body [Front (93), Rear (96)] with a clean, soft, lint free cloth.

7. Fill the shock body (93) (96) with shock oil (94) level to the bottom of the threads.

8. Slide the cartridge (88) along the shaft so there is a 1/2" gap between the hex-end of the cartridge and the top of the lower shock mount (91).

9. Screw cartridge (88) into shock body (93) (96) until o-ring is completely in, being careful not to pinch it in threads.

10. Check to see that the piston travel is full, if it stops prematurely, crack open the shock by turning the cartridge (88) a quarter turn to the left. Slowly force the shock shaft (87) (99) down to its full travel. While the shock is under compression, retighten the cartridge (88).

11. Assure freedom of movement of piston (92).

12. Press the 1/4" shockmount ball (58) into the lower shock mount (91). Snap the shock cup (95) onto the shaft (87) (99) and down onto the lower shockmount (91) as shown.

13. Slide the spring [Front (97), Rear (124)] down over the shock to rest on the lower shock cup (95).

* *NOTE: Blue firm springs on rear shocks.*

14. Insert 4-40 x 3/8" socket head screw (7) into the larger clamp hole of the shock collar (98) and thread into small hole.

15. With the collar (98) loose, slide it down over the top of the shock body (93) (96) and tighten.

* *NOTE: Do not over-tighten the collars to the point of distortion.*

BAG E (Cont.) SHOCK ASSEMBLY

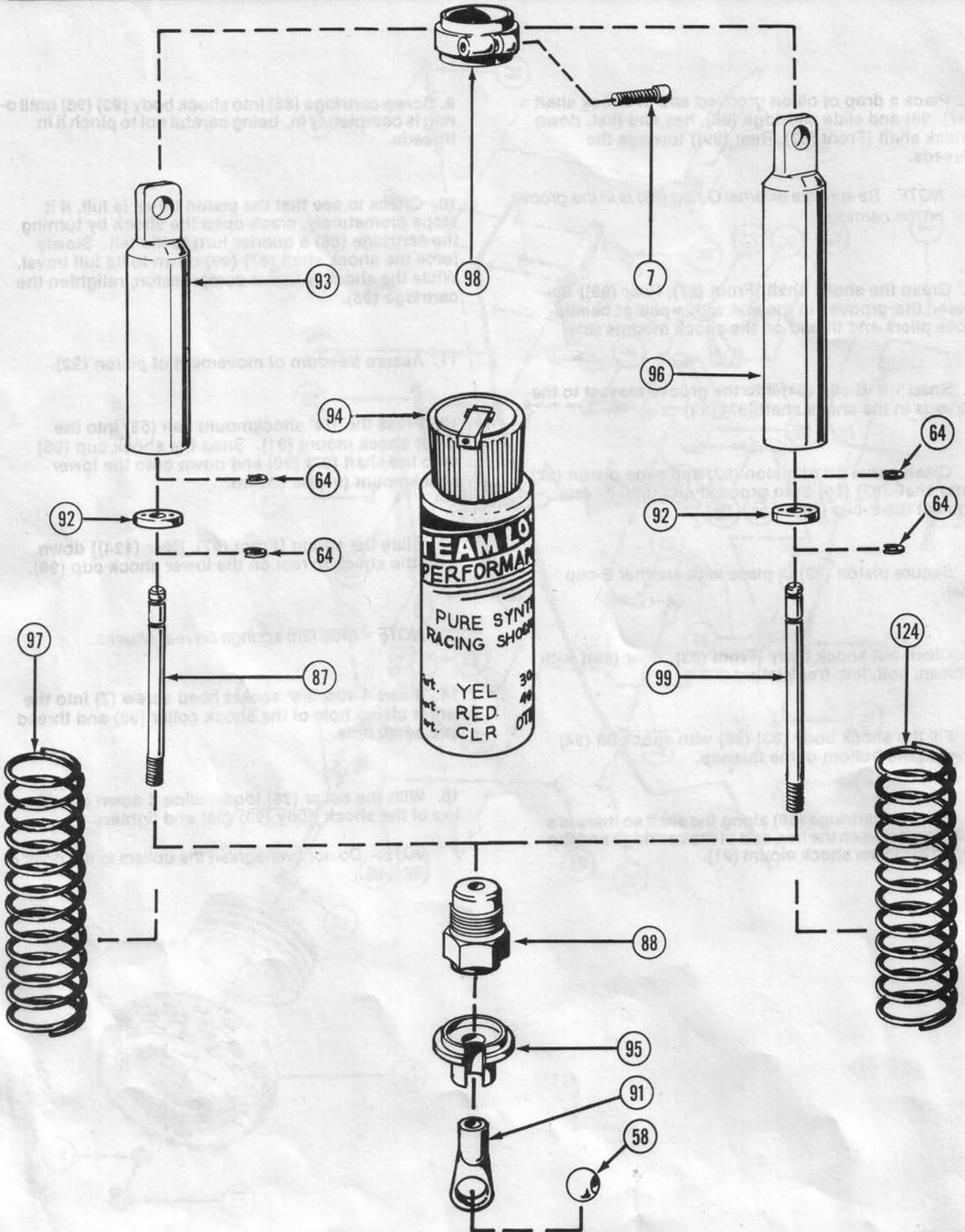

REAR SHOCK ATTACHMENT

1. Thread 4-40 x 5/8" socket head screw (122) through 1/4" shock mount ball (58), H-Arm spacer (11) and into middle hole in H-Arm (1) (123). Fig. 36.

* NOTE: Use the smaller spacer to begin with.

2. Place top of shock body (96) on top shock mount (56) on shock tower (5). Fig. 36.

3. Secure shock with 4-40 nylon nut (51). Fig. 36

* NOTE: It is convenient to rotate shock collars (98) so they are available for adjusting on the car.

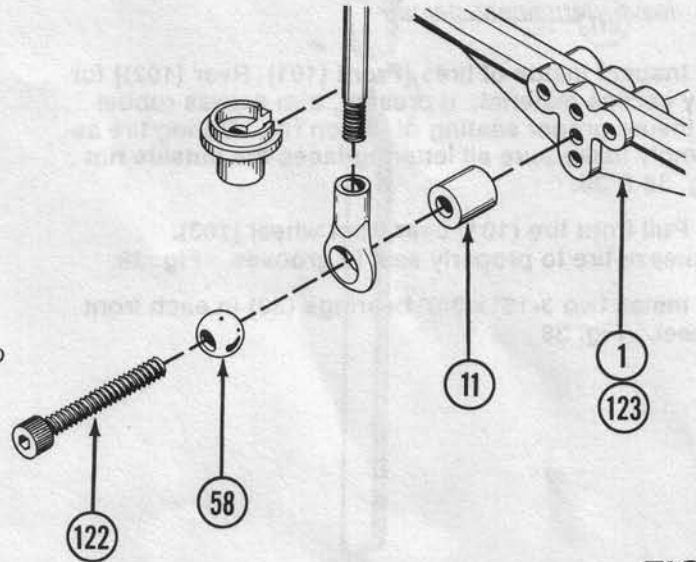

FIG. 36

FRONT SHOCK ATTACHMENT

4. Align 1/4" ball (58) in lower front shock mount (91) with inside hole in front A-arm (78). Fig. 37

5. Thread a 4-40 x 1/2" socket head screw (36) into front of A-arm (78) through shock mount and into other side of A-arm. Fig. 37.

6. Place shock body (93) on front shock mount (56) and secure with 4-40 nylon nut (51). Fig. 37.

7. Repeat steps 1-6 for other side of car.

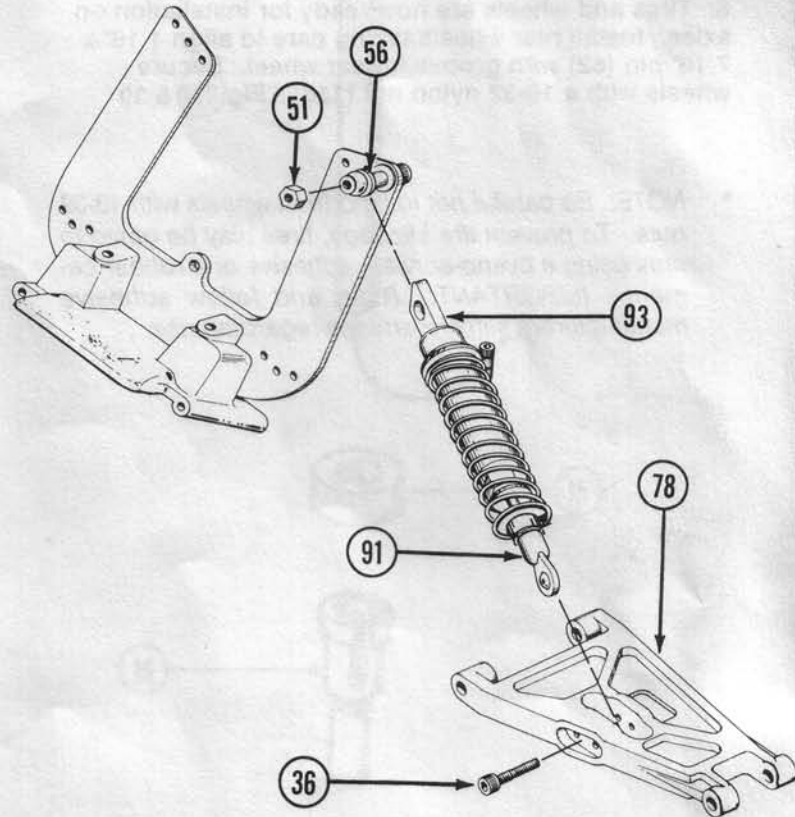

FIG. 37

1. Locate and open Bag F.

* *NOTE: Do not set tires upon furniture as they may leave permanent stains.*

2. Inspect inside of tires [Front (101), Rear (102)] for any excess material. If present, trim excess rubber to insure proper seating of tire on rim. During tire assembly make sure all lettering faces the outside rim. Fig. 38 & 39.

3. Pull front tire (101) over front wheel (103). Squeeze tire to properly seat in grooves. Fig. 38.

4. Install two 3/16" x 3/8" bearings (30) in each front wheel. Fig. 38

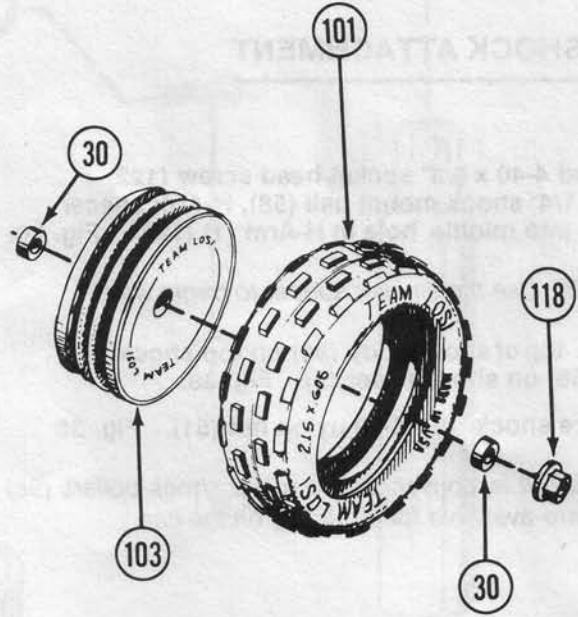

FIG. 38

5. Repeat step 3 on rear tires (102) and rear wheels (100). Fig. 39.

6. Tires and wheels are now ready for installation on axles. Install rear wheels taking care to align 1/16" x 7/16" pin (62) with groove in rear wheel. Secure wheels with a 10-32 nylon nut (118). Fig. 38 & 39

* *NOTE: Be careful not to bind front wheels with 10-32 nuts. To prevent tire slippage, tires may be glued to rims using a cyano-acrylate adhesive or a rubber cement. IMPORTANT: Read and follow adhesive manufacturers safety warnings regarding use.*

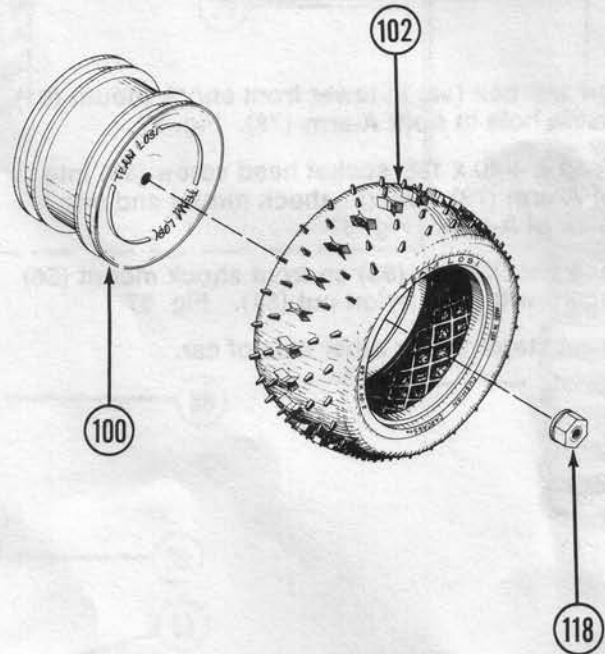

FIG. 39

GEAR COVER-

1. Attach motor to motor plate (40) using 3mm x 8mm socket head screws (111) and two #4 washers (50).

2. Attach pinion to motor shaft making sure set screw is against flat in motor shaft.

* *NOTE: The gears need some backlash in order to function properly.*

3. Locate trimmed gear cover (107) onto motor plate (40) and secure with 4-40 nylon nut (51) on top forward screw (49). Thread a 4-40 x 1/8" button head screw (52) in rear lower hole.

* *NOTE: Trimming outlines for wing, gear cover and body on page 21.*

4. Remove cap (15) from antenna (16) on chassis (2). Fig. 7.

5. Thread antenna wire through tube (109) so that 3/4" of the wire extends outside the tube (109). Fig. 40.

6. With wire position into slot in mount (16) place end of antenna tube (109) into mount (16), making sure wire is free and tube (109) is secure. Fig. 40.

7. Slide antenna mount cap (15) down over antenna tube (109) and snap onto mount (16). Fig. 40.

8. Fold wire end down over antenna tube (109) as secure with antenna tip (110). Fig. 40.

IMPORTANT: It is vital that you properly adjust differential before running car. Refer to turning tips for proper procedure

BODY PAINTING

Prepare the Lexan body shell and wing by washing thoroughly with warm water and liquid detergent. Dry with a clean soft cloth. Use the window template tape masks supplied to cover the windows from the inside. A high grade masking tape or frosty type Scotch tape should be used on the inside to mask off any stripes, panels and designs that you wish to paint on the body. Use acrylic lacquer or acrylic enamel or any of the Lexan (polycarbonate) recommended paints. Apply paint to the inside of the body and the underside of wing. Remove the tape for the next color, etc. Try to use the darker colors first. If you use a dark color after a lighter color, apply a coat of white over the lighter color first.

Cut out the stickers you wish to use and, before removing the protective backing, find your desired location. Remove the backing completely and re-attach an edge of the sticker to a shiny edge of the backing. Using the rest of the backing as a handle, move the sticker into place and press firmly to complete its application.

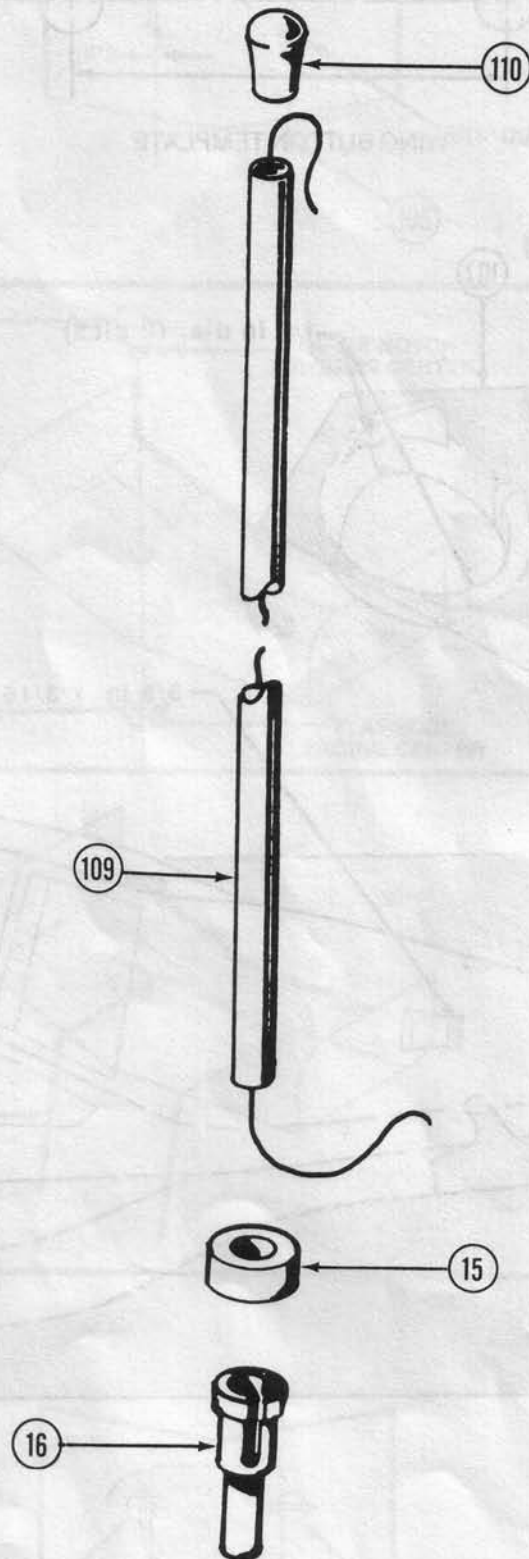
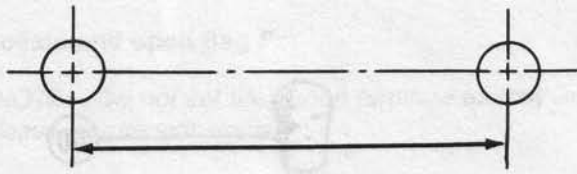
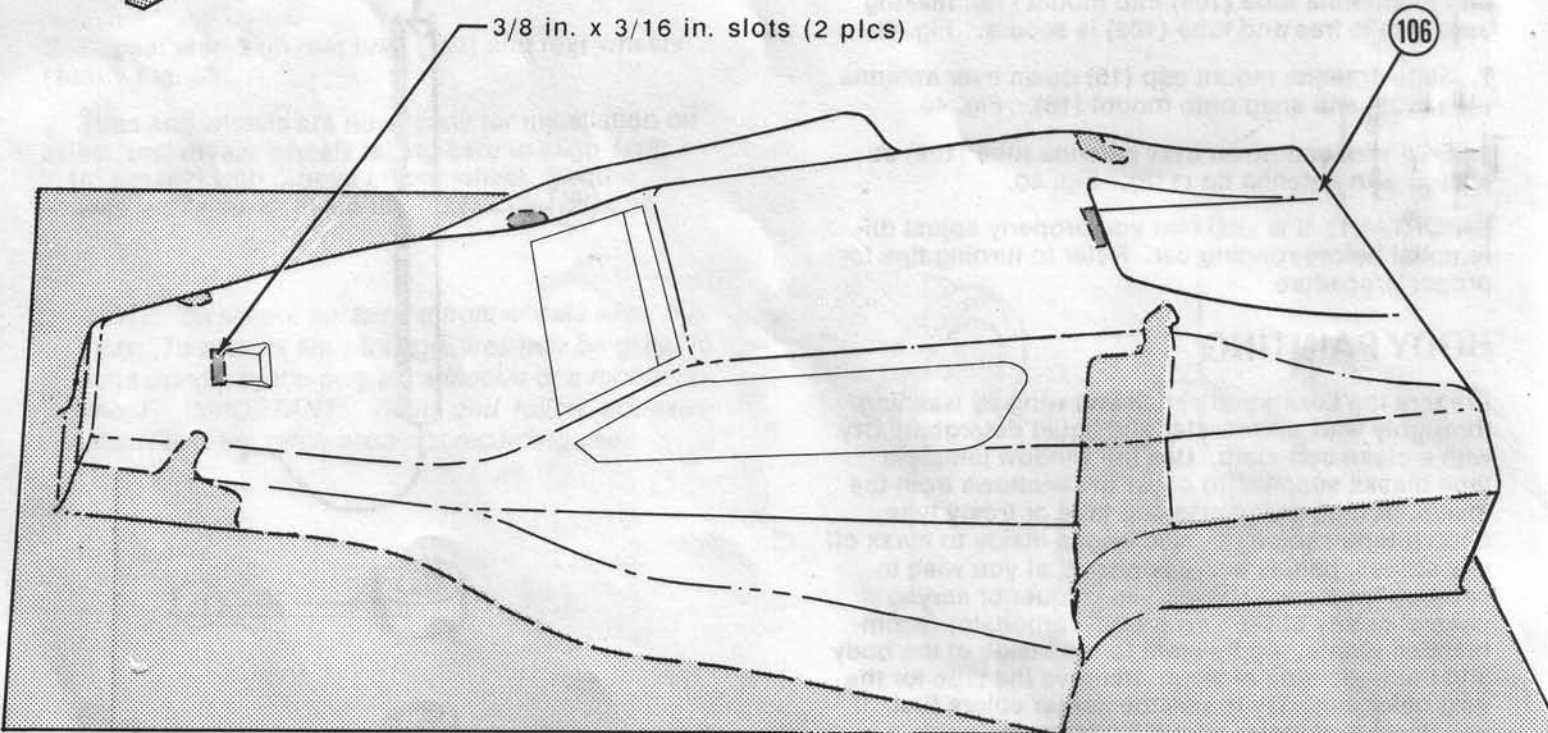
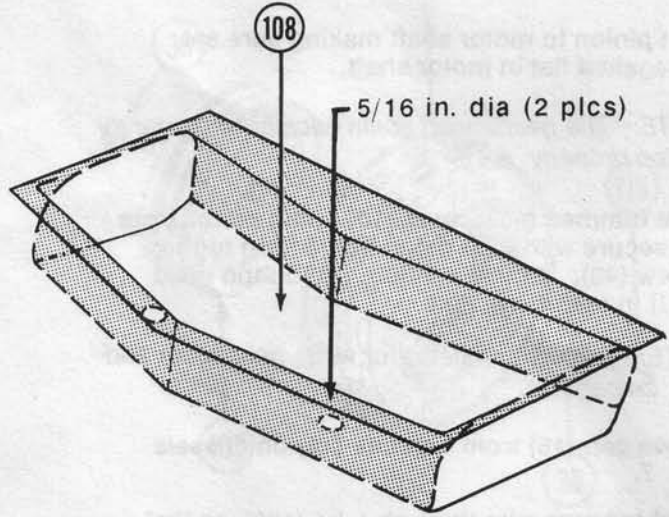
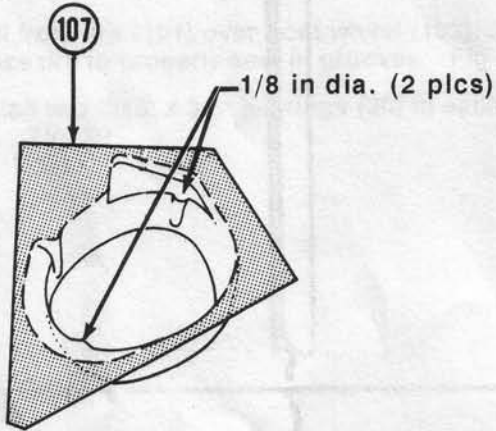

FIG. 40

WING, BODY, GEAR COVER TRIMMING



WING BUTTON TEMPLATE



1. Attach trimmed body (106) to chassis using body clips.

1. Place the bent U-shaped wing wire (105) on the bottom side of the wing (108) in the position you wish it mounted. Fig. 42.

2. Measure 1/8" to the outside of both sides of the wire and drill two 5/16" dia. holes as shown in Fig. 42.

* NOTE: A template is provided on page 21 for location of wing buttons.

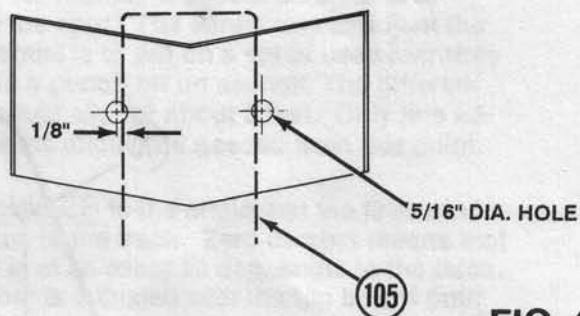

FIG. 42

3. Insert the male top wing button (116) through the top of the wing (108) and snap into the female bottom wing button (121) so that the flat, wire holding edges, are pointing inward toward each other. The top wing button (116) is turned so that the large notch is also pointing inward as shown in Fig. 43.

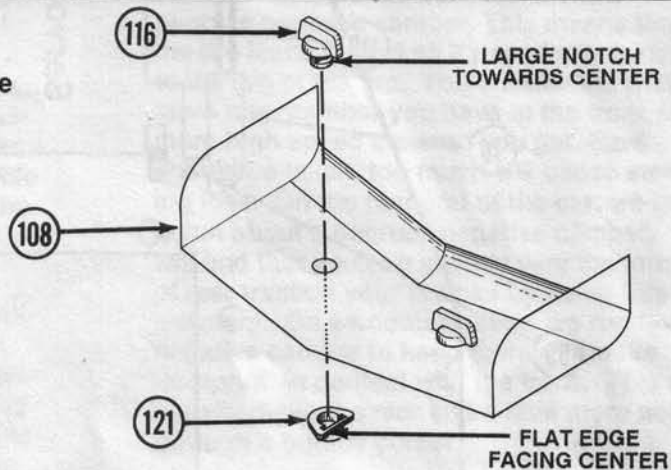

FIG. 43

4. Insert the wing wire (105) from the back through the wing buttons (116) (121) until the wing is in the desired position and bend wire (105) to suit. Fig 44

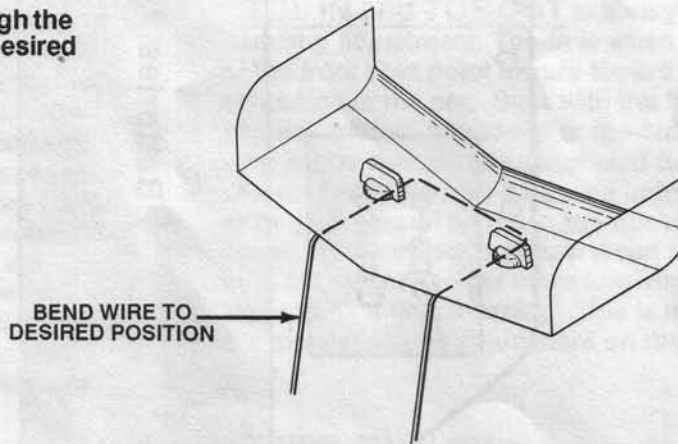

FIG. 44

5. To lock the wing (108) in position, rotate the top wing button (116) 1/4" turn clockwise until the tabs point front to back as shown in Fig. 45.

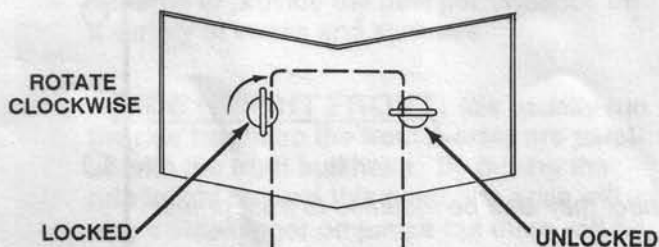
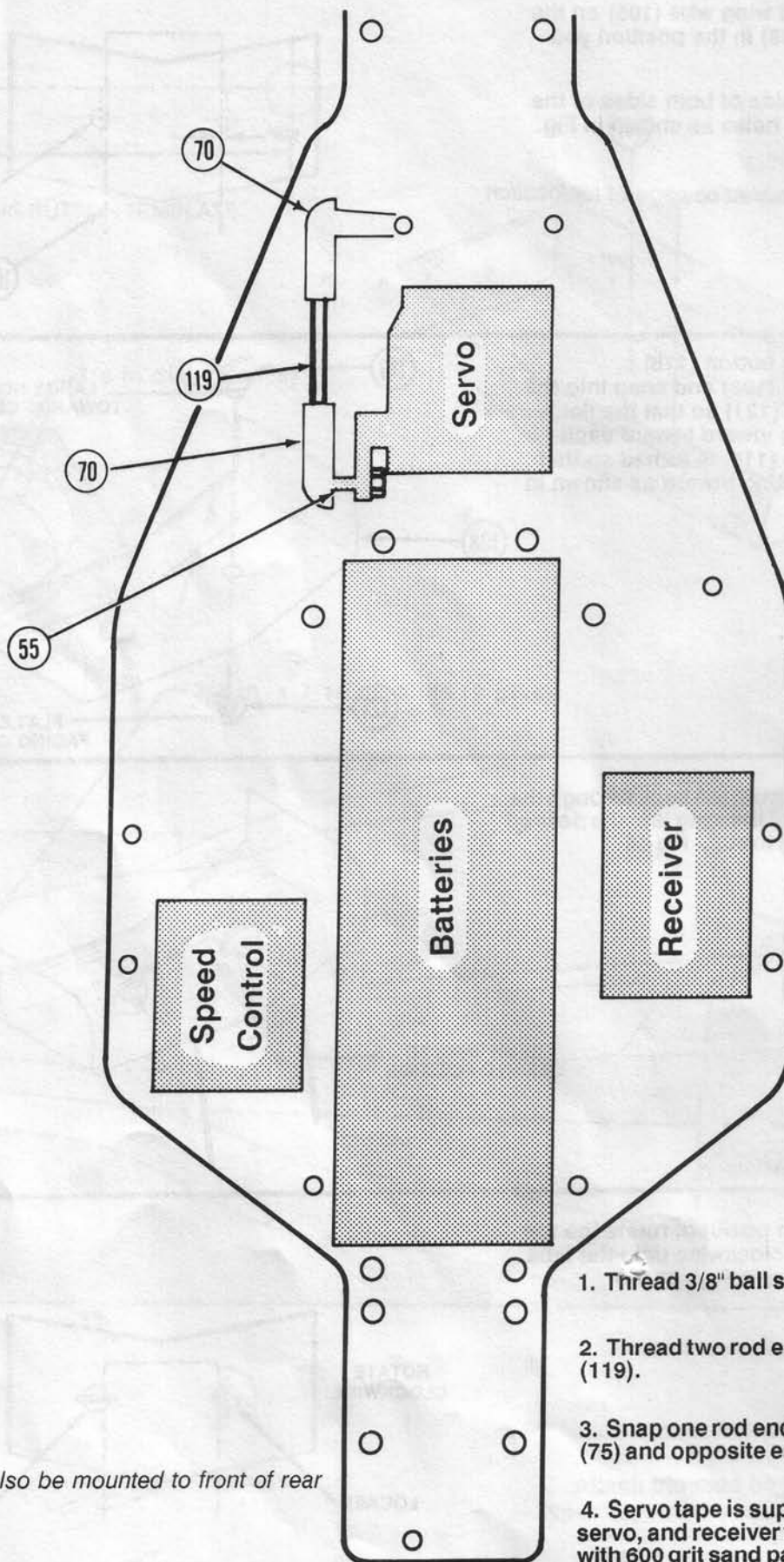

FIG. 45



Speed control may also be mounted to front of rear hock tower.

1. Thread 3/8" ball stud (55) into servo arm.

2. Thread two rod ends (10) onto threaded servo rod (119).

3. Snap one rod end (70) onto ball stud in bell crank (75) and opposite end into ball stud in servo arm.

4. Servo tape is supplied to secure speed control, servo, and receiver to chassis. Lightly sand chassis with 600 grit sand paper and wipe clean to prepare surface.

TUNING TIPS FROM GIL LOSI JR.

THE GEAR BOX is the heart of every race car. The JRX-PRO is no exception. Although the JRX-PRO transmission is very efficient, there are certain adjustments that are necessary for top performance. The differential is most important. Many different types of greases were tested and the one we found to be the best was included in the kit. This type of grease works extremely well and allows the differential to run fairly loose for slick track conditions. Too much grease can cause the differential to bind. When you assemble the differential, it should feel free and rotate smoothly. Wipe off any excess grease and, if necessary, apply some light oil to the sides of the center gear to loosen it up.

ADJUSTING THE DIFF Tighten the differential adjustment screw only until slight torque is felt prior to installation into the gear box. When making adjustments, start off by making a 1/4 turn, then 1/8 turn adjustments for fine tuning. I also suggest that you turn the differential between adjustments to avoid flat spots. The actual final setting will vary with track conditions.

On a slippery track, a looser differential will help give more controlled acceleration. Do not run the differential too loose or damage will occur. I have won many major races on slippery tracks by changing to a milder motor or 6 cells rather than relying on a slipping differential. A loose differential setting will generally give you more off power steering and a bit less on power steering. A tighter differential setting is just the opposite in that you will get a bit less off power steering and more on power steering.

For the serious racer who wants an even looser diff., Team Losi offers "hard balls" (Part #4016, 4017). These balls use the stock grease on the thrust bearing assembly and Jammin' diff lube in the diff gear. Maintenance required for this set-up includes cleaning the balls, thrust washers and holes in the center diff gear with a pipe cleaner after every weekend of racing. If the proper maintenance is followed, washers and balls will have a considerably longer life span.

To adjust the differential, use a 5/64" allen wrench through the adjusting hole on the left side of the gear box. Turn clockwise to tighten, counter clockwise to loosen the ad-

justment screw. To check the pressure, hold both rear tires and try to rotate the spur gear with your thumb. It should be difficult to move the spur. The surest way to adjust the differential is to put on a set of used rear tires and do a punch off on asphalt. The differential should slip for about 2 feet. Only fine adjustments should be needed from this point.

CAMBER is the angle that the tires run in relation to the track. Zero camber means that a tire is at an exact 90 deg. angle to the track. Camber is adjusted with the top link of both the front and rear suspension. Normally on the front end, we run between 2 and 5 degrees negative camber. This means that the tire leans inward as it rises from the track to the top of the tire. You should find that the more neg. camber you have in the front, the more high speed steering you get. Care should be taken, too much will cause steering loss. On the rear end of the car, we usually run about 3 degrees negative camber. You will find that you can slightly vary the amount of rear traction your car has by using this adjustment. On smoother tracks, we run less negative camber to keep more of the tire "footprint" in contact with the track. This will usually make the rear end a little more solid through a bumpy corner.

TOE IN and TOE OUT is a very critical handling adjustment. Toe-In is when the front of the front tires point inward toward the centerline of the car. Start with the front tires parallel, without any toe-in or toe-out. By adding a little toe-out, the car should turn more at low speed, but may be a little unforgiving exiting corners. Too much toe-out will scrub speed. If the tracks is slippery, run a little toe-in. This makes the car more forgiving and takes away a little steering. This is perhaps the most sensitive adjustment on the JRX-PRO.

TIRES TEAM LOSI tires are made of real rubber compounds and should work well on most track surfaces. Most tires are available in both HT and K compounds. All of the tires use innovative and carefully engineered tread patterns to provide the best performance on a variety of tracks and surfaces.

RIDE HEIGHT FRONT: We usually run the ride height so the front A-arms are parallel with the front bulkhead. By raising the ride height beyond this point, the nose will stay a little bigger on jumps but there will be a little less steering. We very rarely run the ride height lower than parallel.

RIDE HEIGHT REAR: We normally run with the drive shafts pointing upward slightly. When inspecting the ride height, make sure to gauge it off of the drive shaft and not the H-arms. This is a fairly standard setting and is only varied to keep the chassis from bottoming out.

SPRINGS The springs provided in this kit are soft for the front and firm for the rear. For the front, soft springs gain low speed steering. Firmer springs will provide high speed steering and will also allow you to brake harder while going into a corner. On the rear, a stiffer spring makes the car more agile and it will respond quickly to throttle and steering input. The car will also stay flatter in sweeping turns with good traction, but it will be harder to set up on rough tracks.

REPLACEMENT SPRINGS Using computer aided engineering, Team Losi springs are designed specifically for the operating range of the shock accessories. Each spring has a designed spring rate and each has been certified to ensure the finest quality. Only the best materials, ASTM A228 and ASTM A302 are used and all springs are color coded for quick and easy identification.

DAMPING is the friction like quality of a shock absorber. Changing the viscosity of the shock fluid will change the damping ability of the shock absorber. A heavier shock fluid will prevent the shock from compressing as quickly as it would with a light fluid. When setting the car up for a track, the first thing to do is to make the car handle the jumps consistently. If the car noses off of the jumps, you can either lighten the front damping by using a lighter thinner oil or increase the rear damping by using a heavier thicker oil. Here are some things to consider when deciding what to do:

1. Higher front damping will give you more steering into a turn but less out. It also carries the front-end higher in the bumps.
2. Heavier front damping will provide the opposite results of light front damping.
3. Higher rear damping will make the car more agile but will also allow more weight to transfer quicker across the car. This results in less traction and the lifting of the inside front tire.
4. Heavier front damping will tend to be just right but if it's too heavy, you will lose steering and the car will hop in the small ruts.

FRONT SHOCK LOCATION We normally run the bottom of the shock to the inside hole on the "H-Arm". The top of the shock is usually to the outside of the tower. By moving the tip of the shock towards the inside, the car will turn in a little harder but will be a little less forgiving.

FRONT CAMBER LOCATION We run the front camber link to the center hole. Moving it outward gives the car a little less steering. Moving it inward gives it a little more steering.

REAR SHOCK LOCATION We run the bottom of the rear shock in the bottom hole of the arm. The top of the shock is usually in the bottom outside hole of the tower. By moving the shock to different locations you will get different shock ratings. This will cause the shock to "pack" either more or less. Generally the less "pack" it has, the better it will work in choppy conditions, but will usually bottom out when landing on jumps. The more "pack" it has, the better it will land on jumps but it may hop a little in choppy conditions. The suggested location works pretty well for most situations, but by experimenting you may find one better for your conditions.

REAR CAMBER LOCATION We run the inside rear camber link in the lower inside hole on the new shock tower. Compared to the stock locations, the car goes through bumps better and is a little more "locked-in". On the rear hub, we normally run the link in the center inside (toward the middle of the car) hole. We have found these to work best under most conditions. For outer hinge pin location, the top hole seems to work best for us. By changing the location of the link and/or hinge pin, you can achieve a wide range of adjustments. Although the mentioned locations worked best for us, you may find a combination that suits your driving style.

REAR TOE-IN, ANTI-SQUAT Two of the most important, yet subtle suspension tuning adjustments, the JRX-PRO includes a selection of rear pivot supports to cover a variety of track conditions. Each of the supports offers a different combination of toe-in and anti-squat. When a car undergoes hard acceleration, the rear end has a tendency to drop. When this happens, the car loses some of its on-power traction. In order to overcome this, the anti-squat ability of the car must be increased. The drawback is that

as the anti-squat increases the forward traction, it also decreases the off-power traction.

If the rear end of the car has a tendency to "skate" or is unstable, then adding toe-in would give the car more straight line stability and help solve this problem. The trade-off to having toe-in is a decrease in straight line speed and the car will not carry speed through the turns as well. Each adjustment made to a car creates a trade-off. Performance is gained in one area and lost in another. The trick is to find the best set of trade-offs for your driving style.

On the back of each pivot support, there will be a number. This number corresponds to the style of the pivot support. Refer to the chart provided to determine the toe-in and anti-squat for each support.

On the bottom of the H-Arm, you will find a letter and an arrow. The arrow points to the

front of the car and the letter designates left and right. You'll notice that the arms are swept back slightly and that there are a number of holes for shock placement. If you reverse the arms so that they are swept forward, you will shorten the wheelbase and speed up the reaction time of the car. If you raise the shock placement, the car will handle big jumps better and be less forgiving in chop and turns. Use the adjustments provided, experiment and find out which combination works best for you.

The suggestions given in this kit should be used only as general guidelines. There are so many variables in a car that they cannot possibly be listed in a simple instruction sheet. Go to the track, try out various combinations of set-ups and get a feel for what each one does to the handling of the car.

Good luck with your new JRX-PRO. I'm sure you will be pleased with it's performance.

TABLE 1

REAR PIVOT SUPPORT REFERENCE TABLE

Use the following table as a reference in conjunction with the "REAR TOE-IN, ANTI-SQUAT" information in the Tuning Tips for selection of the rear pivot support:

<u>STYLE</u>	<u>TOE-IN</u>	<u>ANTI-SQUAT</u>
VERSION 1	6.0 deg.	4.0 deg.
VERSION 2	6.0 deg.	1.7 deg.
VERSION 3	5.0 deg.	4.0 deg.
VERSION 4	5.0 deg.	1.7 deg.

TABLE 2

RECOMMENDED GEARING FOR TEAM LOSI MOTORS

<u>MOTOR</u>	<u>MODEL NO.</u>	<u>PINION</u>	<u>SPUR</u>
Big Ed	TL 6108	18	86
Super Insane	TL 6109	14	86
Wet Magnet 4	TL 6102	19	86
Stock	TL 6060	23	86
MTM (Truck)	TL 6104	21	86
Jr's Choice	TL 6103	20	86
Motown Missile	TL 6106	16	86

*This is recommended gearing for Team Losi Motors. Ratios can be adjusted depending on various track layouts and battery styles.

Toe In / Toe Out & Camber

DISTANCE A LESS THAN B = TOE IN
DISTANCE B LESS THAN A = TOE OUT

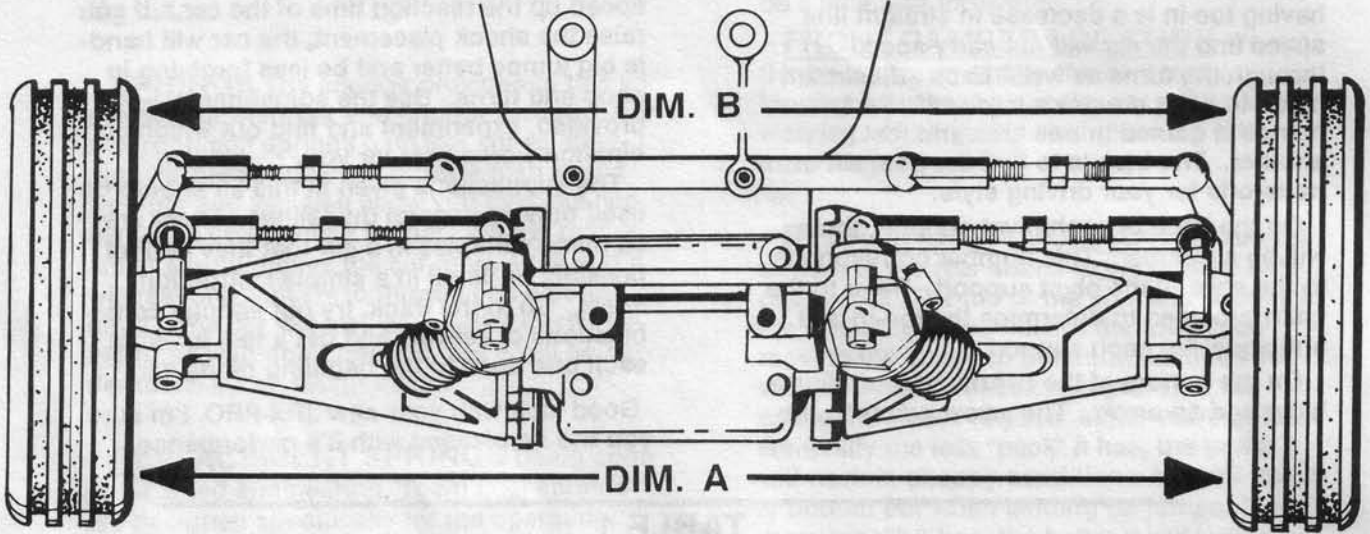

TOP VIEW

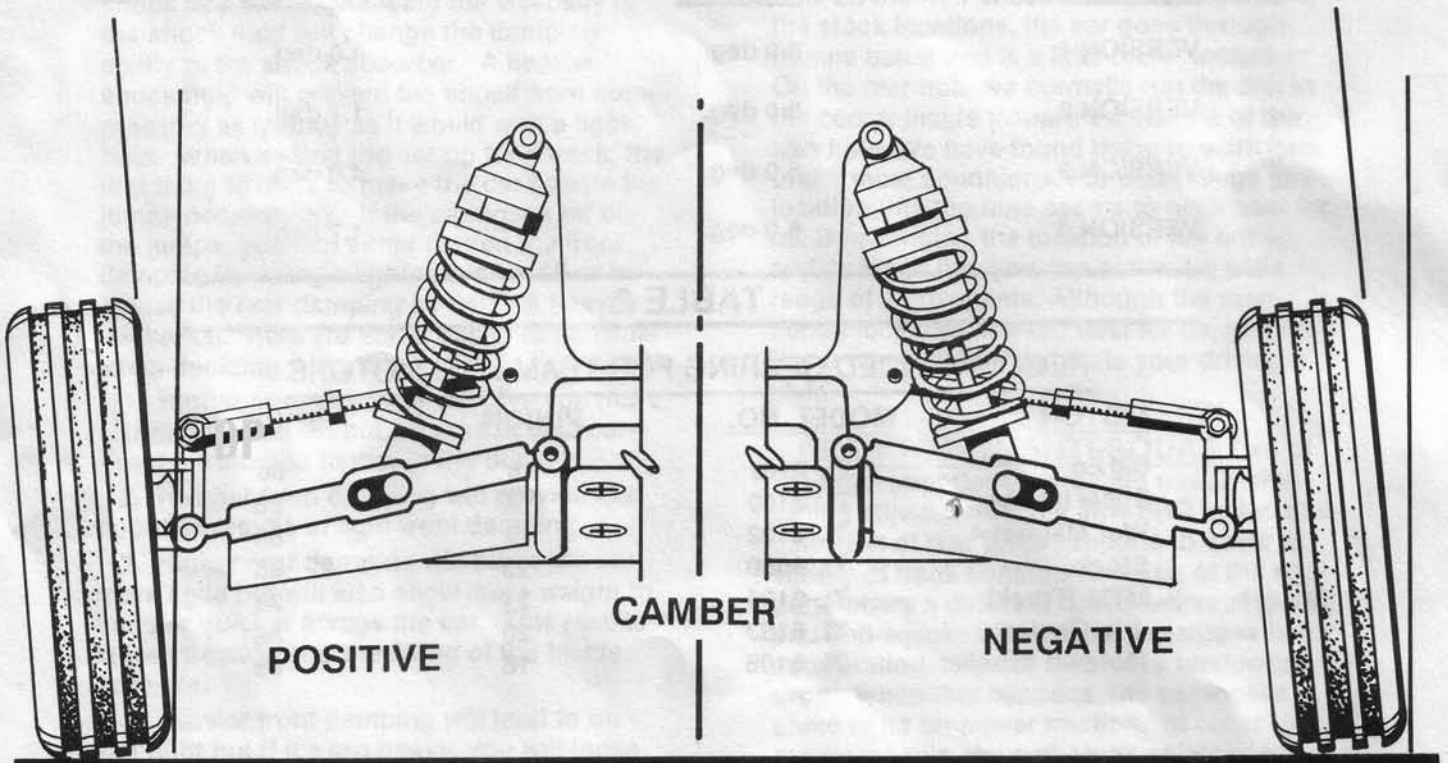

CAMBER

FRONT VIEW

Appendix A-Hardware Identification Guide

SCREWS

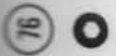

#4-40 x 1/8" HEX
SOCKET HEAD
WITH SHOULDER



3mm x 8mm HEX
SOCKET HEAD

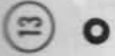

5-40 SET SCREW

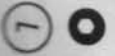

#4-40 x 3/8" HEX
SOCKET HEAD

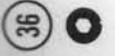

#4-40 x 1/2" HEX
SOCKET HEAD



#4-40 x 5/8" HEX
SOCKET HEAD



#4-40 x 7/8" HEX
SOCKET HEAD



#4-40 x 1 3/8" HEX
SOCKET HEAD



#4-40 x 1 3/4" HEX
SOCKET HEAD



#4-40 x 1/4" FLAT
HEAD 100 deg
COUNTERSINK



#4-40 x 3/8" FLAT
HEAD 100 deg
COUNTERSINK



#4-40 x 1/2" FLAT
HEAD 100 deg
COUNTERSINK



#8-32 x 1/2" FLAT
HEAD 100 deg PHILLIPS
COUNTERSINK



#4-40 x 1/8" ROUND
HEX SOCKET HEAD



#5-40 x 3/4" ROUND
HEX SOCKET HEAD

WASHERS



.130 x .400 DIFF.
THRUST WASHER



.390 x .128
BELLEVILLE
WASHER



#4-40 NUT
ZINC PLATED



#5-40 HEX
JAM NUT



#4-40 NYLON HEX
WASHER HEAD NUT



#10-32 NYLON HEX
WASHER HEAD NUT



REAR AXLE
SPACER



SMALL H-ARM
SPACER



OUTDRIVE SPACER



BALL STUD
WASHER

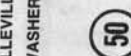

#4 WASHER

Appendix A-Hardware Identification Guide

RODS



#4-40 x 1 1/2"
THREADED ROD
(119)



#4-40 x 1 1/2"
THREAD ROD
WITH HEX DRIVE
(86)



#4-40 x 1 7/8"
THREADED ROD
WITH HEX DRIVE
(71)

SHAFTS



EXTRA LONG SHOCK SHAFT
(99)



SHOCK SHAFT
(87)

BEARINGS & BALLS



(32)



8mm x 14mm
BEARING
(30)



(27)



(58)



(29)



5/16" x 1/2"
BEARING
(19)



(38)



(64)

3/16" x 3/8"
BEARING

.128 x .400
THRUST BEARING
CAGE

1/4" (.250) BALL WITH
THRU HOLE

BALL STUDS



(55)



(72)

#4-40 x 3/8"
STUDED BALL

#4-40 x 3/16"
STUDED BALL

3/16" (.187) E-CLIP

1/8" (.125) E-CLIP

PINS

1/16 x 7/16 ROLL PIN

(42)

1/16 x 7/16 SOLID PIN

(62)



(44)

3/32" x 1/2" ROLL PIN

(84)

.125 x .690 KING PIN

(85)

.125 x .960 HINGE PIN

(66)

.125 x 1.420 HINGE PIN

(79)

.125 x 1.650 HINGE PIN



(63)

.125 x 1.785 HINGE PIN

3/16" (.187) E-CLIP

1/8" (.125) E-CLIP

SPARE PARTS LIST

KEY NO.	ITEM DESCRIPTION	PART NO.	CONTENTS
1	H-ARM RIGHT	A-2014	H-ARM (LFT & RT) (1)
2	CHASSIS	A-4000	CHASSIS (1)
3	4-40 x 3/8" FLATHEAD	A-6210	4-40 x 3/8" FLATHEAD (10)
4	STEERING POSTS	A-1500	STEERING POSTS W/ HARDWARE (2)
5	REAR SHOCK TOWER	A-2009	REAR SHOCK TOWER (1)
6	REAR BULKHEAD	A-2001	REAR BULKHEAD (1)
7	4-40 x 3/8" SOCKETHEAD SCW	A-6206	4-40 X 3/8" SOCKETHEAD SCREW (10)
8	8-32 x 1/2" FLATHEAD ALUM SCW	A-6209	8-32 x 1/2" FLATHEAD (10)
9	FRONT SHOCK TOWER	A-1004	FRONT SHOCK TOWER (1)
10	FRONT BULKHEAD	A-1003	FRONT BULKHEAD (1)
11	H-ARM SPACER	A-2015	H-ARM SPACER (2)
12	PLASTIC SNAP CLIP	A-2021	PLASTIC SNAP CLIP (2)
13	5-40 SET SCREW	A-4011	5-40 SET SCREW (10)
14	BATTERY BOX	A-4001	BATTERY HOLDER (1)
15	ANTENNA MOUNTING CAP	A-4002	ANTENNA KIT (1)
16	ANTENNA MOUNT	A-4002	ANTENNA KIT (1)
17	CENTER DIFFERENTIAL GEAR	A-3006	DIFFERENTIAL GEAR (1)
		A-3005	TRANS MOLDED GEAR SET (1)
		A-3000	COMPLETE TRANSMISSI (1)
18	3/32 DIFFERENTIAL BALLS	A-3009	DIFFERENTIAL BALLS (12)
19	1/4" x 3/8" BEARING	A-6901	BEARING (1)
20	FEMALE HALF OF DIFFERENTIAL	A-3000	COMPLETE TRANSMISSION (1)
21	MALE HALF OF DIFFERENTIAL	A-3005	TRANS MOLDED GEAR SET (1)
22	5-40 LOCKNUT	A-3000	COMPLETE TRANSMISSION (1)
		A-3018	THRUST BEARING ASSEMBLY (1)
		A-6302	5-40 x 3/4" BUTTONHEAD SCREWS (4)
23	HEX THRUST WASHER	A-3000	COMPLETE TRANSMISSION (2)
24	5-40 x 3/4" BUTTON HD. SHLDR SCREW	A-3000	COMPLETE TRANSMISSION (1)
		A-3018	THRUST BEARING ASSEMBLY (1)
		A-6211	5-40 STEEL LOCK NUTS (4)
25	BELLEVILLE CONE WASHER .128 x .390	A-3000	COMPLETE TRANS (3)
		A-3018	THRUST BEARING ASSEMBLY (1)
26	THRUST WASHER	A-3000	COMPLETE TRANS. (1)
		A-3018	THRUST BEARING ASSEMBLY (2)
27	THRUST BEARING CAGE	A-3000	COMPLETE TRANS. (1)
		A-3018	THRUST BEARING ASSEMBLY (1)
28	1/16" THRUST BALL BEARINGS	A-3000	COMPLETE TRANSMISSION (8)
		A-3018	THRUST BEARING ASSEMBLY (8)
		A-3019	1/16" THRUST BALLS (8)
29	5/16" x 1/2" BEARINGS	A-3000	COMPLETE TRANS. (2)
		A-6900	5/16" x 1/2" S.S. BEARING (2)
30	3/16" x 3/8" BEARINGS	A-3000	COMPLETE TRANSMISSION (1)
		A-6903	3/16" x 3/8" BEARING (2)
31	RIGHT HALF OF GEARBOX	A-3000	COMPLETE TRANSMISSION (1)
		A-3001	TRANSMISSION HOUSINGS (LFT & RT) (1)
32	8mm x 14mm BEARINGS	A-3000	COMPLETE TRANSMISSION (2)
		A-6902	8mm x 14mm BEARINGS (2)
33	OUTPUT GEAR	A-3000	COMPLETE TRANSMISSION (2)
		A-3005	TRANS. MOLDED GEAR SET (2)
34	OUTDRIVE SPACER	A-3000	COMPLETE TRANSMISSION (1)
		A-3017	REAR OUTDRIVE SPACER (2)
35	U-JOINT OUTDRIVE	A-3000	COMPLETE TRANSMISSION (2)
		A-3013	MOLDED U-JOINT SET (2)
36	4-40 x 1/2" SOCKET HEAD SCREW	A-3000	COMPLETE TRANS. (2)
		A-3013	MOLDED U-JOINT SET (2)
		A-6204	4-40 x 1/2" SCREWS (10)

37	LEFT HALF OF GEARBOX	A-3000	COMPLETE TRANSMISSION .(1)
		A-3001	TRANS. HOUSING (LFT & RT) (1)
38	3/16" E-CLIPS	A-3007	INTERNAL PRIM. GEAR W/HDWR (1)
		A-1500	STEERING POSTS W/ HDWR (2)
		A-6101	3/16" E-CLIPS (12)
39	PINION SHAFT	A-3007	INTERNAL PRIM. GEAR W/HDWR
40	MOTOR PLATE	A-3002	MOTOR PLATE (1)
		A-3000	COMPLETE TRANSMISSION (1)
41	4-40 x 1 3/8" SOCKETHEAD SCREW	A-3000	COMPLETE TRANS. (3)
		A-6203	4-40 x 1 3/8" SCREW (4)
42	1/16" x 7/16" SPIROL PIN	A-3007	INTERNAL PRIM. GEAR W/HDWR (1)
		A-3015	REAR AXLE, WASHER, PIN (1)
		A-6401	1/16" x 7/16" SPIROL PIN (6)
43	SPUR GEAR	A-3886	86 TOOTH 48 PITCH (1)
44	3/32" x 1/2" SPIROL PIN	A-6400	3/32" x 1/2" SPIROL PINS U-JOINT (8)
45	UNIVERSAL PIVOT JOINT	A-3014	UNIVERSAL PIVOTS (2)
46	FEMALE DRIVE SHAFT	A-3013	MOLDED UNIVERSALS SET (2)
47	REAR PIVOT SUPPORT	A-2002	REAR PIVOT PIN SUPPORT (1)
48	4-40 x 1/4" FLATHEAD SCREW	A-6213	4-40 x 1/4" FLATHEAD SCW (6)
49	4-40 x 1 3/4" SOCKET HEAD SCW	A-6202	4-40 x 1 3/4" SOCKETHEAD SCREW (4)
50	#4 WASHER	A-3000	COMPLETE TRANSMISSION (2)
		A-6201	3mm x 8mm SCREWS (10)
51	4-40 NYLON NUT	A-6301	NYLON 4-40 NUTS (10)
52	4-40 x 1/8" BUTTON HEAD SCW	A-6212	4-40 x 1/8" BUTTONHEAD (4)
		A-3000	COMPLETE TRANSMISSION (1)
53	SERVO TAPE	A-4004	SERVO TAPE (3)
54	DUST COVER	A-3003	DUST COVER (1)
55	3/8" STUDED BALL JOINT	A-1000	FT. SUSPENSION W/O SHKS
		A-1503	SERVO. ROD. ADJ. W/ENDS (1)
		A-6000	BALLS STUDED W/ROD ENDS (4)
56	SHOCK MOUNTS	A-5000	FRONT SHOCK KIT (2)
		A-5008	SHOCK MOUNT BUSHING (4)
57	4-40 x 7/8" SOCKET HEAD SCW	A-6216	4-40 x 7/8" SOCKETHEAD SCREW (10)
58	1/4" BALL	A-2006	1/4" BALLS (10)
59	HUB CARRIER	A-2000	HUB CARRIER (2)
60	REAR AXLE	A-3015	REAR AXLE. WASHER & PIN (1)
61	MALE DRIVE SHAFT	A-3013	MOLDED UNIVER. SET (2)
62	1/16" x 7/16" SOLID PIN	A-3015	REAR AXLE. WASHER & PIN (1)
		A-6401	1/16" x 7/16" PINS (6)
63	1/8" x 1.785 HINGE PIN	A-2008	INNER HINGE PIN REAR (2)
64	1/8" E-CLIP	A-1000	FT. SUSPENSION W/O SHOCKS (12)
		A-6100	1/8" E-CLIPS (12)
65	REAR SHOCK TOWER SPACER	A-2009	REAR SHOCK TOWER SPACER (1)
66	1/8" x 1.420 HINGE PIN	A-2007	PRO HUB HINGE PIN (2)
67	REAR AXLE SPACER	A-3015	REAR AXLE, WASHER, PIN (1)
68	WING TUBES	A-2010	WING TUBES (2)
69	BUMPER	A-4045	BUMPER (1)
70	ADJUSTABLE ROD END	A-6002	ADJUSTABLE ROD ENDS (10)
		A-1000	FT. SUSPENSION W/O SHOCKS (4)
		A-1503	SERVO ROD ADJ. W/ENDS (2)
		A-6001	BALLS STUDED W/ROD ENDS (10)
71	1 7/8" TURNBUCKLE	A-2005	TOP REAR SUSPENSION LINK W/ENDS (4)
72	3/16" STUDED BALL JOINT	A-6001	BALLS STUDED W/ROD ENDS (4)
73	BRASS WASHERS	A-6215	BRASS WASHERS (10)
74	STEERING SECTOR ARM	A-1502	STEERING SECTOR ARM W/SCREWS (1)
75	STEERING BELL CRANK	A-1505	MONSTER TRUCK BELL CRANK KIT (1)
76	4-40 x 1/8" SHOULDER SCREW	A-1502	STEERING SECTOR ARM (1)
		A-6200	4-40 x 1/8" SHOULDER SCREW (4)
77	IDLER ARM	A-1505	MONSTER TRUCK BELLCRANK KIT (1)

78	A--ARM	A-1000	FT. SUSPENSION W/O SHOCKS (2)
79	1/8" x 1.650 HINGE PIN	A-1001	A-ARMS (2)
		A-1000	FT. SUSPENSION W/O SHOCKS (2)
		A-1007	BULKHEAD HINGE PINS (2)
80	FRONT AXLE	A-1000	FT. SUSPENSION W/O SHOCKS (2)
		A-1005	FT. AXLES W/NUTS (2)
81	SPINDLE LEFT	A-1000	FT. SUSPENSION W/O SHOCKS (2)
		A-1002	FT. SPINDLES CARRIERS (2)
82	SPINDLE RIGHT	A-1000	FT. SUSPENSION W/O SHOCKS (2)
		A-1002	FT. SPINDLES & CARRIERS (2)
83	SPINDLE CARRIER	A-1000	FT. SUSPENSION W/O SHOCKS (2)
		A-1002	FT. SPINDLES & CARRIERS (2)
84	1/8" x .690 HINGE PIN	A-1000	FT. SUSPENSION W/O SHOCKS (2)
		A-1006	1/8" x .690 KING PINS (2)
85	1/8" x .960 HINGE PIN	A-1000	FT. SUSPENSION W/O SHOCKS (2)
		A-1008	FT. OUTER HINGE PINS (2)
86	1 1/2" TURNBUCKLE	A-1000	FT. SUSPENSION W/O SHOCKS
		A-1009	FRONT TIE ROD (2)
87	LONG SHOCK SHAFT	A-5005	LONG SHOCK SHAFT (1)
		A-5001	REAR SHOCK KIT (2)
88	SHOCK CARTRIDGE	A-5006	SHOCK CARTRIDGE (1)
89	O-RING (SHOCK CART.)	A-5006	SHOCK CARTRIDGE (1)
90	PINION GEAR	A-3007	PINION GEAR
91	LOWER SHOCK MOUNTS	A-5009	CLAMP COLLARS & CUPS. FT (2)
92	PISTON	A-5007	SHOCK PISTONS & E-CLIPS (4)
		A-5001	REAR SHOCK KIT (2)
93	SHOCK BODY (LONG)	A-5003	SHOCK BODY LONG (1)
		A-5001	REAR SHOCK KIT (2)
94	SHOCK OIL	A-5203	FLUID 20 WT. (1)
95	SHOCK CUP	A-5009	SPRING CLAMPS & CUPS. FT (2)
96	X-LONG SHOCK BODIES	A-5021	X-LONG SHOCK BODIES (1)
97	LONG SOFT SILVER SPRINGS	A-5100	FT. S.S. SPRINGS SOFT (2)
98	SHOCK COLLAR	A-5001	REAR SHOCK KIT (2)
99	X-LONG SHOCK SHAFTS	A-5022	X-LONG SHOCK SHAFTS (1)
100	REAR WHEEL	A-7112	REAR WHEEL (2)
101	FRONT TIRE	A-7210	FRONT TIRE (2)
102	REAR TIRE	A-7321	REAR TIRE (2)
103	FRONT WHEEL	A-7012	FRONT WHEEL (2)
104	4-40 x 1/2" FLATHEAD SCREW	A-6220	4-40 x 1/2" FLATHEAD SCW (6)
105	WING WIRE	A-8101	WING WIRE (1)
106	BODY JRX-PRO	A-8010	JRX-PRO BODY (1)
107	GEAR COVER	A-3003	GEAR COVER (1)
108	WING	A-8102	WING (1)
109	ANTENNA TUBE	A-2010	WING TUBES (2)
110	ANTENNA TIP	A-4003	ANTENNA TIPS (8)
111	3mm x 8mm MOTOR SCREW	A-6201	3mm x 8mm (10)
112	BATTERY BOX LID	A-4001	BATTERY BOX (1)
113	8-32 x 3/8" FLATHEAD AL. SCREW	A-6208	8-32 x 3/8" SCREWS (10)
114	BODY CLIP	A-8200	BODY CLIPS (12)
115	8-32 x 1/2" STEEL FLATHEAD SCREWS	A-6218	8-32 x 1/2" STEEL FLATHEAD SCW (10)
116	WING BUTTONS TOP	A-8102	WING BUTTONS TOP
117	4-40 NUT	A-1000	FT. SUSPENSION W/O SHOCKS (2)
118	10-32 NYLON NUT	A-6303	NYLON LOCKING NUTS (8)
119	SERVO ROD	A-1000	FT. SUSPENSION W/O SHOCKS (1)
120	GREASE	A-3012	DIFFERENTIAL LUBE (1)
121	WING BUTTONS BOTTOM	A-8102	WING BUTTONS BOTTOM (1)
122	4-40 x 5/8" SOCKETHEAD SCREWS	A-6203	4-40 x 5/8" SOCKETHEAD SCW (4)
123	H-ARM LEFT	A-2015	H-ARM LFT & RIGHT
124	SPRING FIRM	A-5107	RR SPRINGS FIRM BLUE (2)
125	BATTERY FOAM	A-4001	BATTERY HOLDER (1)

OPTIONAL ACCESSORIES

SHOCK FLUIDS

A-5200	5wt. FLUID
A-5201	10wt.
A-5204	30wt
A-5205	40wt.
A-5206	50wt.
A-5207	70wt.
A-5210	5 PACK (5-40wt.)

WHEELS

A-7010	FRNT LOGO WHEELS ORNGE (2)
A-7011	FRNT LOGO WHEELS NAT (2)
A-7012	FRNT LOGO WHEELS RED (2)
A-7013	FRNT LOGO WHEELS YELLOW
A-7110	REAR LOGO WHEELS ORNGE (2)
A-7111	REAR LOGO WHEELS NAT (2)
A-7112	REAR LOGO WHEELS RED (2)
A-7113	REAR LOGO WHEELS YELLOW (2)

GEARS

A-4178	SPUR 7&T 48P
A-4182	SPUR 82 T 48P
A-3982	82 TOOTH PROFILED SPUR
A-3986	86 TOOTH PROFILED SPUR
A-3990	90 TOOTH PROFILED SPUR

BEARING

A-6904	1/4" x 3/8" THIN BEARING
--------	--------------------------

SPRINGS

A-5106	RR SS MED (GREEN) (2)
A-5108	RR SS X-SOFT (RED) (2)
A-5107	RR SS FIRM (BLUE) (2).
A-5141	RR PROGRESSIVE (BLK) (2)

TIRES

A-7200	FRONT TIRE RIBBED (K) (2)
A-7201	FRONT TIRES RIBBED (HT) (2)
A-7210	FRONT STAGGER RIB (K) (2)
A-7211	FRONT TIRES STAGGER (HT) (2)
A-7221	FRONT TIRES 6 ROW SPIKE (HT) (2)
A-7300	REAR KIT 4 ROW SPIKE (K) (2)
A-7301	REAR KIT 4 ROW SPIKE (HT) (2)
A-7311	REAR 6 ROW VARI-SPIKE (HT) (2)
A-7321	REAR X-PATTERN (HT) (2)
A-7331	REAR 5-ROW SPIKE (HT) (2)
A-7351	REAR 6-ROW SPIKE (HT) (2)

MISC

A-6304	10-32 LOW PROFILE ALUM NUTS (G)
A-4005	MINI BUMPER KIT
A-4016	3/32 HARD DIFF BALLS (12)
A-4017	1/16 HARD DIFF BALLS (8)
A-1504	BALL BEARING STEERING KIT
A-3019	WHITE SUPER SLIDER DRIVE SHAFT
A-3020	BALL BEARING DIFF GEAR KIT
A-3021	BALL BEARING DIFF GEAR ONLY

MAINTENANCE SCHEDULE

PARTS ON JRX-P	EVERY HOUR	EVERY 1.5 HOURS	EVERY 3 HOURS	EVERY 4 HOURS
Oil in shocks	Replace			
Shock cartridges	Check, replace if stiff, leaky			
Wheel bearings	Check, clean or replace as needed			
Transmission outdrive bearings		Check, clean, replace as needed		
U-joint sliders		Replace		
Front arms	Check for binds, clean			Check for wear and play
Rear H-arms				
Rear bulkhead				
Rear pivot support				
Ball joints				
Differential *	If using silicon greases, clean when gritty	Clean out old grease and regrease		
Diff drive rings		Check for wear		
Standard diff balls *		Replace		
Center diff gear		Check for wear		
Outer diff gear		Check for wear		
Outdrive gears				Check for wear
Top trans gear		Check for wear	Replace	

*If using Team Losi Hard Balls. 20-30 hours of run time before replacing with normal maintenance. If drive rings get gritty, the balls can be damaged.

*A new locknut (Item #A-6302) when reassembling your differential.

TEAM LOSI
PERFORMANCE

TEAM LOSI INC., POMONA, CA 91766

Copyright ©

Printed in the United States of America.

800-0024